

PHASCOPE® PMP10 DUPLEX



PHASCOPE® PMP 10 DUPLEX

One-step measurement of a paint/zinc coating system on steel or iron substrate and measurement of lacquer coatings on aluminum

Document order number	Version	Issue date
912-532	1.1	10-2010

Instrument manufacturer:

Helmut Fischer GmbH	Phone: +49 (0)7031 303-0
Institut für Elektronik und Messtechnik	Fax: +49 (0)7031 303-710
Industriestraße 21	www.helmut-fischer.com
D-71069 Sindelfingen	mail@helmut-fischer.de

On our home page www.helmut-fischer.com you will find the addresses of our sole agencies and subsidiary companies around the globe.

Quality Assurance System of the Helmut Fischer GmbH

DIN ISO 17025	Calibration lab with DKD accreditation according to DIN ISO 17025 for certified mass per unit area standards
ISO 9001	Certified subject to ISO 9001 German Lloyd Certification

© 2010 by Helmut Fischer GmbH Institut für Elektronik und Messtechnik, Germany.

This operator's manual remains the copyrighted property of Helmut Fischer GmbH. All rights reserved. This manual may not be reproduced by any means (print, photocopy, microfilm or any other method) in full or in part, or processed, multiplied or distributed to third parties by electronic means without the written consent of Helmut Fischer GmbH.

Subject to correction and technical changes.

PHASCOPE® is a registered trade mark of the Helmut Fischer GmbH Institut für Elektronik und Messtechnik in Germany and/or other countries.

Note: The fact, that the trademark characters ® and ™ may be missing does not indicate that such names are free trademarks.

1	Important Notes - Please Observe!	1
1.1	Intended use	1
1.2	Requirements on the operating personnel	1
1.3	Power connection	1
1.4	Environment conditions	2
1.5	Instrument or accessory repairs	3
1.6	Probes	3
1.7	Calibration standards	4
1.8	Warranty	4
2	Description of Instrument and Accessories	5
2.1	Areas of application	5
2.2	Functional principle/data organization	5
2.3	Front and rear view	6
2.4	Control panel	7
2.5	Display	9
2.6	Softkeys	10
2.7	Connectors	14
3	Operation	15
3.1	Switching the instrument On/Off	15
3.1.1	Automatic shut off	15
3.2	Using the softkeys	16
3.3	Calling a menu function	17
3.4	Calling an application	18
3.5	Moving the cursor on the display page	19
3.6	Scrolling through the display pages	19
3.7	Enabling/Disabling parameters	20
3.8	Selecting parameters	20
3.9	Entries ...	21
3.9.1	Entering numbers	21
3.9.2	Entering alphanumeric characters	21
3.10	Ending/Exiting a menu function	23

3.11 Delete	23
3.12 Cancelling a menu function	24
3.13 Calling the evaluation menu	24
3.14 Calling the block result menus	25
3.15 Viewing Measurements	26
3.16 Air value measurement	26

4 Setting the Language 27

5 Battery 28

5.1 Charging the battery using the AC adapter	28
5.2 Replacing the plug adapter at the AC adapter	30
5.3 Removing the battery from the instrument	32
5.4 Connecting the battery to the instrument	32
5.5 Charging the battery using the charging station MPG	33

6 Handling of the Probes 35

6.1 Probe connection	35
6.2 Measurement probe models ESG...	37
6.2.1 Measurement on flat specimens	38
6.2.2 Measurement on curved specimens	38
6.3 Assigning a new probe	39

7 Compensation of Variables That Influence the Measurements 43

7.1 Normalization (coating and substrate adjustment)	44
7.1.1 Required Materials/Standards	46
7.1.2 Normalization Procedure	47
7.2 Corrective calibration (adjustment to the specimen)	50
7.2.1 Corrective calibration for Paint/Zn/Fe	52
7.2.2 Corrective calibration for Lacquer/Al	58
7.3 Deleting the corrective calibration	61
7.4 Preparing in-house calibration standards	62

8	Master Calibration	63
8.1	Master calibration for Paint/Zn/Fe	63
8.2	Master calibration for Lacquer/Al	71
9	Measurement	75
9.1	The quick path to measurements	75
9.2	Influencing variables	75
9.2.1	Measurement of duplex coatings on steel or iron	75
9.2.2	Measurement of lacquer coatings on metallic non-ferrous substrate materials	76
9.2.3	Measurements on both ferrous and non-ferrous substrate materials	76
9.3	Making a measurement	77
9.3.1	The following should be observed when performing measurements:	77
9.3.2	Measurement accept	77
9.3.3	Acoustic signals after measurement accept	78
9.3.4	Measurement identification	78
9.3.5	Creating a block	79
9.4	Measurement with "continuous" display	80
9.5	Measurement with external start enabled	81
10	Evaluation	82
10.1	Evaluation of one block	83
10.2	Evaluation across several blocks	84
10.3	Statistical characteristic data	87
10.3.1	Block result	87
10.3.2	Final result	88
10.3.3	Final result	90
10.4	Sum frequency chart	91
10.5	Histogram	92
10.6	Evaluation in the simple display and operating mode	93
10.6.1	Block result	93
10.6.2	Final result	93

- 11 Application (Memory for a Measurement Application) 95**
 - 11.1 Setting up an application 95
 - 11.2 Copying an application 98
 - 11.3 Deleting an application 99
 - 11.4 Securing/Unsecuring an application 101
 - 11.5 Selecting a template for setting up new applications 104
 - 11.6 Linking of applications 106
 - 11.6.1 Enabling the linking mode 107
 - 11.6.2 Disabling the linking mode 108

- 12 Measurement Application Specific Settings . 109**
 - 12.1 Menu function "Application/Modify Application" 112
 - 12.1.1 Selecting the display modes (measurement display) 112
 - 12.1.2 Average display value / outlier monitoring, 113
 - 12.1.3 Specification limits monitoring, 116
 - 12.1.4 Automatic block creation / Offset 117
 - 12.1.5 Entering the application name, 119
 - 12.2 Number of decimal places for the reading 120
 - 12.3 Measurement type ("Display Mode") 121
 - 12.4 Delete all measurement data of an open application . 123
 - 12.5 Delete all measurement data of an open block 124
 - 12.6 View/Hide blocks 125
 - 12.7 Do not store readings 126

- 13 Printing 127**
 - 13.1 Settings for printing 127
 - 13.1.1 Selecting the connected printer model 128
 - 13.1.2 Data output mode for printing 129
 - 13.2 Printing during a measurement 130
 - 13.3 Printing after a measurement 130
 - 13.3.1 Printing the block result after a measurement 131
 - 13.3.2 Printing after a measurement according on the setting in the menu function
 - Output/Output to Printer 132**

13.3.3	Printing the final result after a measurement	133
13.3.4	Printing in the Simple Display and Operating Mode	134
13.3.5	Printing the sum frequency chart after measurement	135
13.3.6	Printing the histogram after measurement	136
13.4	Printing the instrument settings	137
14	Data Transfer Via RS232 Interface	138
14.1	Settings for the data transfer	138
14.1.1	Connector pin-out	139
14.1.2	Setting the data format for the RS232 interface . .	140
14.1.3	Data output to the RS232 interface	142
14.2	Transferring data to the computer during a measurement	144
14.3	Transferring data to the computer after measurement	145
14.4	Transfer from the computer to the instrument	146
14.4.1	Transfer formats	146
14.4.2	Control commands	146
15	Instrument Settings	154
15.1	Enabling/Disabling the signal tone for the measurement capture	157
15.2	Instrument status	158
15.3	Setting the unit of measurement	159
15.4	Type of measurement accept	160
15.5	Toggle between normal and simple display and operating mode	161
15.6	Battery operation time and measurement speed settings	164
15.7	Enabling/Disabling the air value measurement . .	166
15.8	Adjust the display illumination	167
15.9	Setting the date and time	169
15.10	Setting automatic switch-off for battery operation .	170

16 Technical Data 171

18 Malfunction? What To Do 176

19 Glossary (Terms and Formulas) 183

Index 207

1 Important Notes - Please Observe!

1.1 Intended use

The PHASCOPE® PMP10 DUPLEX measuring instrument is exclusively suited for coating thickness measurements. The instrument measures the individual thicknesses of a lacquer coating and primarily a galvanically deposited zinc coating (or another NF coating) on steel or iron in one measurement step. Furthermore, the instrument can be employed to measure lacquer thicknesses on aluminum (or other NF substrate materials). The measuring system recognizes the substrate material automatically.

1.2 Requirements on the operating personnel

Basic knowledge of instrument technology according to DIN 1319 is essential to perform correct measurements and evaluations.

Basic computer knowledge regarding configuration, operation and possibly programming as well as knowledge of the software in use is required when using the instrument in conjunction with a computer.

1.3 Power connection



To prevent damage to the instrument or wrong measurement results due to wrong A/C line voltage, connect the instrument to a power outlet using only the AC power supply provided by Fischer. The A/C line voltage must agree with the A/C line voltage rating on the serial number plate of the AC power supply!

1.4 Environment conditions

EMC

The instrument PHASCOPE® PMP10 DUPLEX complies with the regulations concerning electromagnetic compatibility of instruments (EMC). The measured values are not influenced by the highest level of interference as stated in the standard EN 50082-2 (which makes reference to standards EN 61000-4-2, EN 61000-4-3 and EN 61000-4-4). In particular, the instrument is effectively shielded from electromagnetic fields (e.g., motors, power lines, radio transmission towers).

Ambient temperature during operation: +5 ... +50 °C (+41 ... +122 °F)

Storage and transport temperature: +5 ... +60 °C (+41 ... +140 °F)



Temperatures behind windows (e. g., in cars) in direct sunshine rise easily above +60 °C (+140 °F)! To avoid damage to the instrument or accessories by heat, do not keep or store them in such places.



To avoid the danger of short circuits, instruments and accessories (in particular the AC power supply) must not come in direct contact with fluids!
Instrument and accessories may be operated, kept and stored only in places where the relative humidity is between 30 and 90 % (non-condensing)!



Instrument and accessories are not acid resistant! Avoid direct contact with acid or acid solutions!



We recommend removing the batteries if the instrument is not used over a longer period.
This will prevent potential damage that may be caused by depleted batteries.



Instrument and accessories must not be operated in an explosive atmosphere!



Instrument and accessories must be protected from static charge! Electric discharges can damage internal components or delete internally stored data.



Such discharges can occur, for example, when connecting the probe to the instrument. Thus, the person connecting the probe should be grounded.
It is recommended to store the instrument with the connected probe.

1.5 Instrument or accessory repairs

The battery is the only user-serviceable part of the instrument and the accessories.



Do not open the instrument and the AC adapter!
Categorically, only specialists authorized by Fischer may open the instrument!

1.6 Probes



To avoid breakage of the wiring, do not bend the probe connector cable! The radius of rolled probe connector cables must always be at least $R \geq 50 \text{ mm}$ (2")

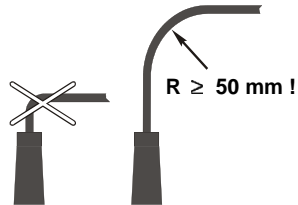

Place the probe speedily yet gently on the specimen surface!
Avoid hard impacts!



Do not drag the probe tip across the surface of the specimen!



Do not place standard probes on hot or acid-covered surfaces, do not immerse them into liquids! Special probe models are available for such applications.

1.7 Calibration standards



To protect the supplied calibration standards from dirt or damage, keep the standards in their case!



To keep wear and tear of the calibration standards to a minimum, use them only for corrective calibration / normalization (adjusting the measurement system to the specimen)! Do not use them for test measurements!

1.8 Warranty

Fischer will assume no warranty claims in the following instances:

- Use of instrument and accessories for purposes other than the intended use.
- Improper handling of instrument and accessories.
- Disregard of operator's manual.

Helmut Fischer GmbH Institut für Elektronik und Messtechnik is not liable for damage resulting from misuse and from repairs or alterations carried out by non-authorized, third parties.

Helmut Fischer GmbH Institut für Elektronik und Messtechnik is not liable for damage or malfunctions caused by the use of options or accessories, which are not original Fischer products or do not have an express approval by Helmut Fischer GmbH Institut für Elektronik und Messtechnik.

2 Description of Instrument and Accessories

Depending on the coating system, the PHASCOPE® PMP10 DUPLEX measures the coating thickness according to the phase-sensitive eddy current method (ISO 21968) and the magnetic induction measurement method (ISO 2178). The measuring system recognizes the substrate material of the specimen automatically and accordingly selects the appropriate measurement method.

2.1 Areas of application

- Measurements of the individual thicknesses of a paint/zinc coating system (NC/NF coating system) on steel or iron. The measurement of the two coatings is carried out in one fast, easy and non-destructive measurement step. Aside from galvanically deposited zinc coatings, hot dip galvanized coatings can be measured only if there are no pronounced diffusion zones between zinc and steel. Hot dip galvanized coatings with pronounced diffusion zones between zinc and steel cannot be measured! For measurements with zinc alloys such as ZnNi, the measurement system must be newly adapted using a corrective calibration (with 2 standards) or even with a master calibration.
- Measurement of lacquer coatings on aluminum (NC/NF).

2.2 Functional principle/data organization

A measurement application is not only defined by the material properties and the geometric shape of the specimen but also by the probe type (measurement method, serial number) in use. A new measurement application exists if one of these quantities changes. A separate memory area, referred to as application, is assigned to each measurement application. An application is defined by an application name and an application number. The following data and settings are stored in an application:

- the correction quantities obtained through substrate/coating material adjustment (= normalization) or adjustment to the specimen (= corrective calibration),
- settings that specify how the measurements are being displayed, stored and evaluated (e.g., monitoring of specification limits or outliers, block

statistics),



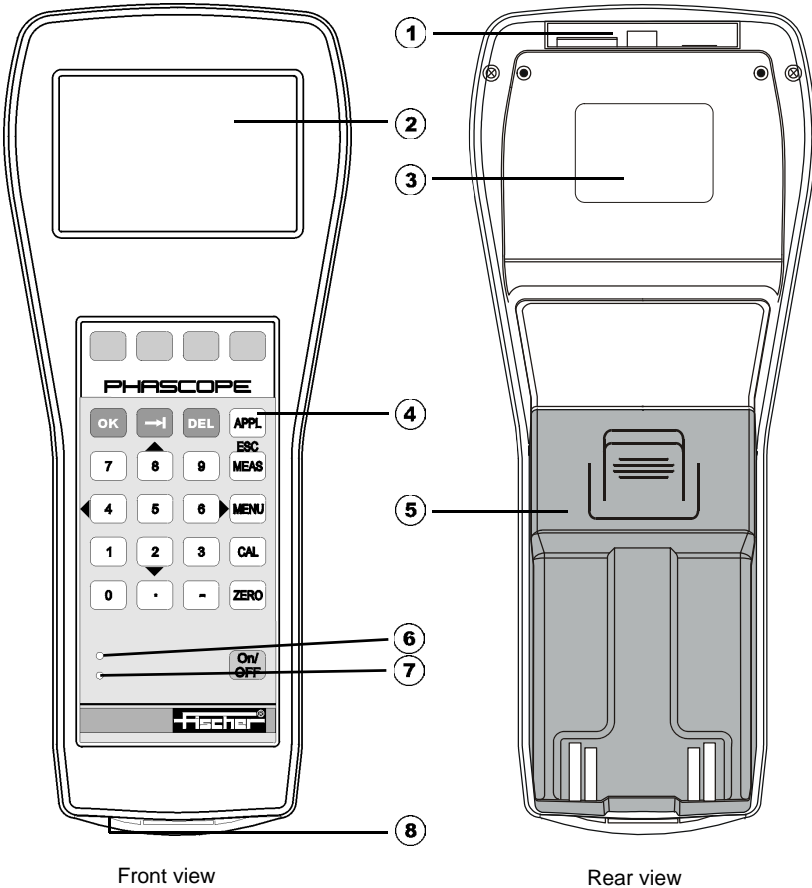

- measurement readings and evaluations.

An application must be set up to make measurements with the PHASCOPE® PMP10 DUPLEX  95.



2.3 Front and rear view





- ① Instrument connection sockets for the measurement probe and the printer or the PC  14.

- ② Display, LCD graphics display, backlit,  Symbols beginning on page 9, Display modes beginning on page 112.
- ③ Name plate
- ④ Control panel,  description of the keys beginning on page 10.
- ⑤ Battery,  handling/charging beginning on page 28.
- ⑥ A lit red LED indicates that the battery is charging.
- ⑦ A lit green LED indicates that the AC adapter is connected to the instrument.
- ⑧ Connector socket for the AC adapter  14.







2.4 Control panel



Key	Function
Unnamed turquoise-colored key surfaces	Softkeys - the respective functions of these keys are shown at the bottom of the display.  10.
OK	<ul style="list-style-type: none"> ● Confirms the selection or setting shown in the display (saves the settings).
	<ul style="list-style-type: none"> ● Moves the cursor within a display page to the next parameter, entry or selection window. ● External start enabled: Measurement accept
DEL	<ul style="list-style-type: none"> ● Deletes the last measurement/displayed value. ● Deletes a character during the entry procedure.
APPL	<p>Calls the application selection menu; the selection of the application is carried out via the softkeys or by direct numeric entry.</p> <p>Pressing the key several times in the application selection menu: calls the probe type, the number of measurements and the used probe frequency for the selected application.</p>

Key	Function
ESC MEAS	Quits a menu function. Changes to the measurement mode of the current application. Changes made to settings are disregarded.
MENU	Calls the selection menu of the menu functions; the selection of the menu functions is carried out via the softkeys or by direct numeric entry.
CAL	Calls the correction calibration function (adjustment of the measuring system to the specimen).  50.
ZERO	<ul style="list-style-type: none"> ● Calls the normalization function (Coating/substrate material adjustment).  44. ● Assigns a new probe to the current application ("Probe" flashes in the top right corner of the display).  39.
ON/OFF	Switches the instrument On/Off.
0 ... 9	Enters the respective number.
8, 4, 6, 2	Numeric keys with black arrows: Moves the cursor (selection) in the entry and selection window.
.	Enters a comma/period.
-	<ul style="list-style-type: none"> ● Enters a hyphen/minus sign. ● Toggles the character selection field between lower and upper case letters.

2.5 Display





The display format is essentially an alphanumeric one.



Symbol	Explanation
	Battery (flashes): indicates that the battery needs to be recharged because the voltage has dropped below a minimum value.  28 and 33.
Probe	Text (flashes): the wrong probe or no probe is connected to the instrument.  from 35 and 39.
FULL	Text (flashes): The measurement memory is full; no additional readings can be stored.
	Key: Measurement block is closed.
▲	Up arrow (to the left of the reading): Upper set specification limit has been violated.
▼	Down arrow (to the left of the reading): Lower set specification limit has been violated.
#	Pound symbol in the list of applications (to the left of the application name): Secured application, changes to settings and deletions are not possible.  101.
*	<ul style="list-style-type: none"> ● Asterisk in the list of applications (to the left of the application name): secured application; additionally, the normalization and correction calibration functions are blocked.  101. ● Asterisk in the list of menus (to the left of the menu name): Menu function cannot be called at this time.





Symbol	Explanation
	Rectangle in the list of applications (to the left of the application name): The application has been selected as a template. All new applications will be set up using the settings of this marked application.  104.
	Hourglass: instrument-internal routine in progress, e.g., when powering up the instrument.





2.6 Softkeys

The functions of the softkeys change corresponding to the respective display page. The functions are displayed directly above the respective key field (turquoise color) on the display (in the lower black bar).

Softkey (shown on the display)	Function
	Moves the marker (cursor, arrow, line) in entry and selection fields and graphs (e. g. in specification limit mode) to the left .
	Moves the marker (cursor, arrow, line) in entry and selection fields and graphs (e. g. in specification limit mode) to the right .
	Moves the selection (cursor) up .
	Moves the selection (cursor) down .
ALL	Assigns the probe to all linked applications.
BLOCK	Block result of the open or closed block, respectively.  Glossary.

Softkey (shown on the display)	Function
CLOSE	Performs a manual block close .
CONT.OFF	Disables the continuous display mode function .
CONTINUE	<ul style="list-style-type: none"> ● Quits the block result menu without performing a manual block close. ● Quits the menu function / the menu.
CONTR←	Sets the display contrast ; moves the cursor bar to the left.  167.
CONTR→	Sets the display contrast ; moves the cursor bar to the right.  167.
CURR	Assigns a new probe only to the currently open application.
DEL CAL	Deletes the correction calibration (adjustment to the specimen) of the open application memory.
DELETE	<ul style="list-style-type: none"> ● Deletes a selected application or all readings of the open application. ● In the simple display and operating mode: deletes all readings of the open application.
ENTER CH.	Accepts the selected character into the entry field.
ESCAPE	Cancels a function : Switch to the current display mode, changes are not stored/confirmed.
EVALUATE	Opens the Evaluation menu . Use the softkeys to select the desired evaluation presentation (statistical evaluation, histogram, probability chart).  82.
FINAL RES	Calls the evaluation menu in the simple display and operating mode.

Softkey (shown on the display)	Function
GET 	Accepts the air value of the probe.
HISTOGRAM	Evaluation using the Histogram . Presentation of the single readings according to their class proportions (coating thickness ranges).  92 and Glossary.
IMP.STD	Opens the display page for entering the nominal value of the standard.
INTERV.	Shows the required interval ranges (normalized count rates) for the coated standards that are used for the master calibration. Comparison with the normalized count rate of the last measured standard.
LIGHT	On/Off switch for the display illumination .  167.
MEM	Deletes the data of the last measurement series of the corrective calibration (adjustment of the measurement system to the specimen).
ON/OFF	On/Off switch (enabled [X]/disabled []) for the parameters .
PAGE	Scrolls to the next/previous display page or displays additional softkey functions. Changes/entries are retained.
PAGE↑	Scrolls to the previous display page .
PAGE↓	Scrolls to the next display page .
PRINT	Output of the measurements and the statistical evaluation presentation using a connected printer .  from 127.

Softkey (shown on the display)	Function
REPEAT	Repeats the execution of a function (e.g., when assigning a new probe).
RETURN	Scrolls back to the previous display page.
RS232	Starts transfer of the readings and the statistical evaluation via the RS232 interface, e.g., to a PC.  from 138.
E	Evaluation with the normal probability chart (sum frequency chart) . This graphics shows the percentage of the product lot in relation to the measured coating thickness readings.  91 and Glossary.
SECURE	Secures a selected application (a type of write protection, no changes can be made in the application). Unsecure.  102.
STAT.	Statistical Evaluation of the application. mean value, standard deviation, coefficient of variation etc.  from 87 and Glossary.  With automatic block creation, the mean values of the individual blocks are used each time for the statistical evaluation.

2.7 Connectors

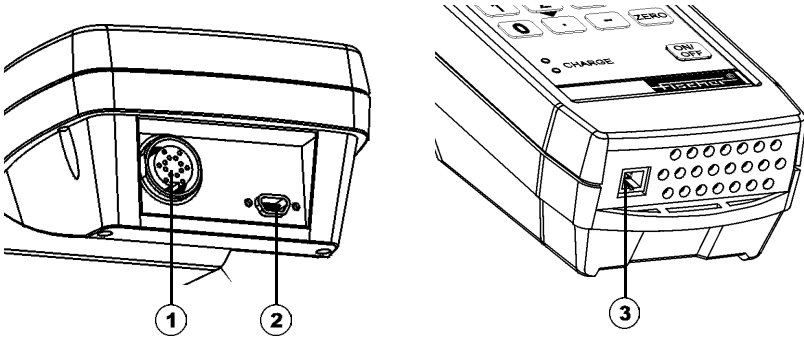

- ① **Connector socket for the probe**  Connection and handling of the probe from page 35.
- ② **Connector socket for Printer or PC (RS232 interface)**

Printer:  from 127.

The following printers with serial port are suitable for operation with the instrument: 9-pin printers, 24-pin printers, laser printers, Kyosha Kyoline, Seiko DPU-411 and DPU-414.

PC:  from 138.

Connection: Connect the instrument to the PC using the RS232 interface (parallel port, COM1 or COM2).

The interface connection kit MP (602-341) includes the proper interface cable. Use the supplied adapter if your PC has a 25-pin connector.

- ③ **Connector socket for the AC adapter**
The AC adapter is used for direct connection of the instrument to line voltage and for charging the battery.  Charging the battery from page 28.

3 Operation

3.1 Switching the instrument On/Off

Keys / Softkeys

Function



Switches the instrument On/Off.

Acoustic signals will sound while an automatic internal self-test is carried out.

The application used prior to shut down is called automatically, and the last reading appears on the display. The instrument is now ready for use. Measurements can be made, or a different application or a function can be selected.



Corresponding to the connected probe, an air value measurement must be performed when opening the application. This is done for measurement reliability.

Hold the probe in the air (at least 2" (5 cm) distance to the closest object) and press the softkey **GET** .

The appearance of this message, and thus the performance of the system adjustment, can be disabled using the menu function **Measurement Options/Air value warning**.  166.

3.1.1 Automatic shut off

With battery operation, the instrument will shut off automatically after a set time if the menu function **System options/Autom. Switch-OFF** is enabled. This function is disabled during AC line operation.

Factory default setting: 5 minutes.

To switch the instrument On again: Press



Information for the menu function **System options/Autom. Switch-OFF**, page 170.

3.2 Using the softkeys

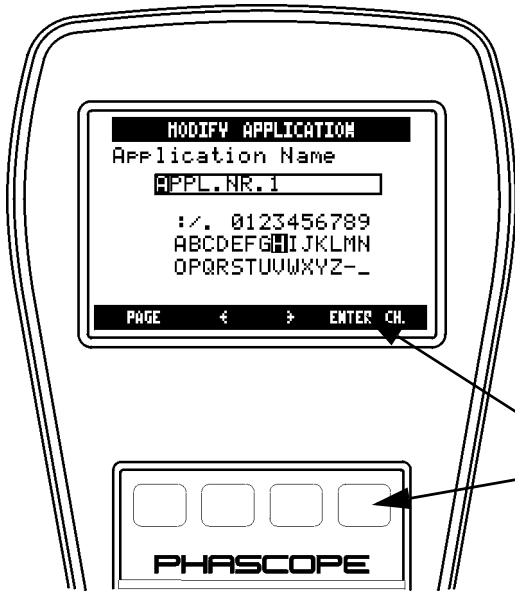

Softkeys are keys with a context-sensitive function, i.e., their functions change corresponding to the shown display page. The respective current function is shown in the bottom black bar of the display and is assigned to the turquoise-colored key directly underneath.











Softkey function

Softkey (turquoise-colored key, Example softkey **ENTER CH.**)

3.3 Calling a menu function

Menu functions are used to configure the instrument and to set-up and edit an application. Some menu functions are protected from unauthorized access by a password, the so-called supervisor code.

The menu functions are sorted in an overview under 7 menu designations.

Key sequence/Action	Explanation
1. 	Press this key. Calls the menu overview.
2.  or  and 	Selects the desired menu.
or	or
 ... 	Press the respective numeric key on the control panel.
3.  or  and 	Calls the desired menu function.
or	or
 ... 	Press the respective numeric key on the control panel.
4.	Carries out the desired entry and settings on the display page(s).





Menu functions that cannot be carried out at the time are identified in the menu list by an asterisk (*) to the left of the menu name.

Example:



*** Delete Block**

In this case, the open application has no open block that could be deleted using this menu function.

3.4 Calling an application

- | Key sequence/Action | Explanation |
|---|--|
| 1.  | Press this key
Calls the application selection menu. |
| 2. PAGE↓ or PAGE↑ | If applicable, scroll first to the page,
where the desired application is listed. |
| 3. ↑ or ↓ and  | Move the selection bar to the desired
application and confirm the selection
with "OK". |

or

- | | | | | | |
|---|-----|---|-----|---|---|
|  | ... |  | and |  | Press the respective numeric keys on
the control panel and confirm the entry
with "OK". |
|---|-----|---|-----|---|---|





Press the  key several times: Calls the probe type, number of measurements and the desired probe frequency for the selected application.

Descriptions of the symbols that may appear  9.









Corresponding to the connected probe, an air value measurement must be performed when opening the application. This is done for measurement reliability.

Hold the probe in the air (at least 2" (5 cm) distance to the closest object) and press the softkey **GET** .

The appearance of this message, and thus the performance of the system adjustment, can be disabled using the menu function **Measurement options/Air reading warning**.  166.

3.5 Moving the cursor on the display page (flashing selection)

Keys / Softkeys	Function
	<p>Jumps from one parameter to the next parameter (activation field [], selection list (), entry field).</p>
<p>↑, ↓, ←, →</p>	<p>Used inside an entry window/selection list and in graphical presentations.</p> <p> If softkey arrow keys are not available, the arrow keys of the control panel will assume these functions.</p>
 ,   , 	<p>Used inside the character field to select the desired character (e.g., for entering a name,  21).</p>

3.6 Scrolling through the display pages

Keys / Softkeys	Function
PAGE	<p>Displays the next display page with new parameters.</p>
PAGE↑	<p>Corresponds to scrolling on the PC monitor. Continue scrolling through the display pages, e.g., to continue through a listing.</p>

3.7 Enabling/Disabling parameters

Brackets are always located to the left of the parameters to be enabled:

[] Monitor Limits

Keys / Softkeys	Function
ON/OFF	<p>Enables/disables a parameter</p> <p>Enabled parameter: [X]</p> <p>Disabled parameter: []</p> <p>The setting is executed or accepted into an application after exiting the menu function.</p>

3.8 Selecting parameters

Parentheses are always located to the left of the parameters to be selected:

() German
 (●) English
 () French
 () Italian
 () Spanish

Keys / Softkeys	Function
↑, ↓	<p>Moves the cursor (point) to the desired parameter.</p> <p>(●) Parameter is selected: the function will be executed or accepted into the application after exiting the menu function.</p> <p>() Parameter is not selected: the function will not affect the application, measurement or instrument setting.</p>

3.9 Entries ...

The display pages of some menu functions contain entry fields for parameters or designations (Name, Feature). Entries may be basic numeric values for parameters or letters and numbers, e.g., for names.

3.9.1 Entering numbers

This section deals with entering numbers only. They may be values for parameters, date, time, etc.

- Entering numbers is done using the numeric keys of the control panel.
- The cursor (dark highlight) will flash in the active entry field.
- Units of measurement are not entered along with the numeric entry.

Entry field (example)



3.9.2 Entering alphanumeric characters (letters, numbers, etc.)

This section deals with entering text that may consist of numbers, letters or a combination of both.

A character field with the available characters appears on the display page (see figure to the side. Example: entering an application name) for entering names or designations.

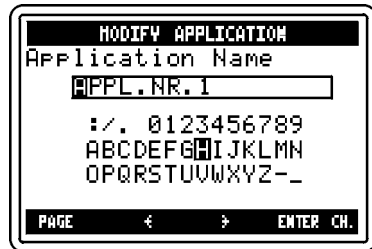

Keys / Softkeys	Function
------------------------	-----------------



Toggles between upper and lower case letters for the character field.

Keys / Softkeys

Function



Selects the desired characters from the character field.



ENTER CH.

Accepts the character selected in the character field into the entry field.

The character is accepted from the character field in the overwrite mode: The highlight in the entry field is overwritten by the selected character (space).



Moves the highlight (cursor) in the entry box.

Overwriting a wrong entry

Keys / Softkeys

Function

1. or

Moves the cursor to the wrong character in the entry field.

2.

Selects the correct character from the character field

ENTER CH.



The highlighted character in the character field is confirmed and overwrites the selected character in the entry field.

3.10 Ending/Exiting a menu function

Ending/exiting a menu function automatically requires calling the open application.

Keys / Softkeys	Function
	Accepts all entries and settings carried out in the menu function. A switch to the measuring mode of the open application occurs automatically.
CONTINUE	Quits a menu function where carried out settings are executed immediately and visibly (e.g., through a message, a note or a listing). Returns to the measuring mode of the open application.

3.11 Delete

Key / Softkeys	Function
	Deletes the character (black flashing rectangle) selected in the entry field.
	Deletes the last measurement .
DEL CAL	Deletes the corrective calibration (adjustment to the specimen) of the open application. When link mode is enabled: deletes the corrective calibration of all linked applications.



Additional delete functions see from page 123.

3.12 Cancelling a menu function



Keys / Softkeys	Function
ESCAPE or 	Cancels a menu function. Entries and settings that have been made will not take effect. A switch to the measuring mode of the open application occurs automatically.

3.13 Calling the evaluation menu

The statistical evaluation is carried out separately for each application. Within an application, the evaluation can be carried out per block or across a selection of x blocks. The evaluation menu assumes the complex mathematical evaluation and, as a result of the measurement, the user receives values that are easy to interpret in a numeric format, in a table, or in a graphical format as in a probability distribution chart and histogram.



Detailed information can be found from page 82.

Keys / Softkeys	Function
EVALUATE	Calls the evaluation menu - carried out from the measuring mode.
 ... 	Enters the desired block numbers.
	Moves the cursor in the display.
STAT.	Shows the statistics for the selected blocks.
Σ	Displays the evaluation in the probability chart.
PAGE	Scrolls to the next display page.



Keys / Softkeys	Function
RS232	Data transfer via RS232 interface.
PRINT	Prints the results.
	Quits the evaluation menu. Returns to the measuring mode of the open application.

3.14 Calling the block result menus





The block result of the last block (either open or already closed), or even of a block set up previously, can be viewed from the block result menu.



Detailed information can be found from page 83.

Keys / Softkeys	Explanation
BLOCK	Calls the block result menu - carried out from the measuring mode.
 , 	Selects the desired block.
CLOSE	Perform a manual block close.
CONTINUE	<ul style="list-style-type: none"> ● Quits the menu without manually closing the block. ● Quits the menu (with automatic block creation).
PRINT	Prints the block result.
PAGE	Scrolls to the next display page and displays additional results.

3.15 Viewing Measurements

Keys /Softkeys	Function
 , 	In the measurement mode, to view the individual measurements of a block in succession.
 , 	

3.16 Air value measurement

Corresponding to the connected probe, an air value measurement must be performed when opening the application. This is done for measurement reliability. A corresponding message appears on the display.



The appearance of this message, and thus the performance of the system adjustment, can be disabled using the menu function **Measurement Options/Air value warning**.  166.





Procedure

Key sequence/Action	Explanation
1. Hold the probe in the air.	The distance to the closest object should be at least 2" (5 cm).
2. GET 	Press this softkey. Switches to the measurement mode of the open application.

4 Setting the Language

This menu function is used to select the desired language for the display.

Procedure

	Key sequence/Action	Explanation
1.	 ,  , 	Press these keys in succession. Calls the menu function System options/ Language .
2.	↓, ↑	Selects the desired language.
3.		Accepts the settings and exits the menu function (= switch to the measuring mode of the active application).

5 Battery

- The battery must be charged before first use and after storage of more than six months. If necessary, this should be carried out twice in order to activate the battery.
- Always keep the contacts of the battery clean!
- Hours of operation: 10 h to 20 h, depending on the settings in the menu **Measurement Options/Low Power Mode**,  164.





When the display lighting is switched on, the operation time of the battery will be reduced significantly corresponding to the brightness setting and the illumination time.

- Charging time: Max. 4 h



Disposal: **Do not dispose of batteries in domestic waste!** Please place used or damaged rechargeable batteries into collection bins intended for this purpose!

- A flashing  symbol in the top right display corner indicates that the battery is discharged and must be replaced ( from 32) or recharged ( 28 or 33).



We recommend removing the batteries if the instrument is not used over a longer period. This will prevent potential damage that may be caused by depleted batteries.

5.1 Charging the battery using the AC adapter

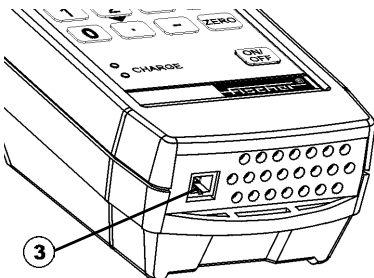

3

Connector socket for the AC adapter

The AC adapter is used to charge the battery and to connect the instrument directly to the line voltage.



The A/C line voltage must agree with the A/C line voltage rating on the serial number plate of the AC power supply!

Use the country-specific line adapter.  Changing the AC adapter, 30.

Procedure

1. Plug the AC adapter into the socket.
 2. Connect the AC adapter to the instrument (see Fig. on page 28). This starts the automatic quick-charge cycle, which is indicated by the lit red LED on the instrument. In addition, the green LED lights, indicating that the instrument is connected to the line voltage.
- It is not possible to overcharge the battery. At the end of the main charge cycle, the mode switches to maintenance charging and the red LED extinguishes.
 - If the battery is exhausted: In this operating mode, charging starts with a reduced main charging current until the battery is regenerated and it is OK to switch to the “normal” main charging mode. The red LED will light only after switching to the "normal" main charging mode.
 - The instrument can remain connected to the line voltage indefinitely when using the AC adapter.



Do not connect the instrument to the line voltage repeatedly within a short period!

Wait at least one hour before reconnecting to the line voltage!

Otherwise the battery and the instrument may be damaged!

5.2 Replacing the plug adapter at the AC adapter

The plug at the AC adapter can be replaced. The plug (= plug adapter) can be replaced according to the country-specific design. The AC adapter will automatically adjust to line voltages between 100 and 240V~ at 47 to 63 Hz.

As an example, the replacement of the plug adapter Euro to the plug adapter US is described below. The plug adapters are included with the AC adapter.

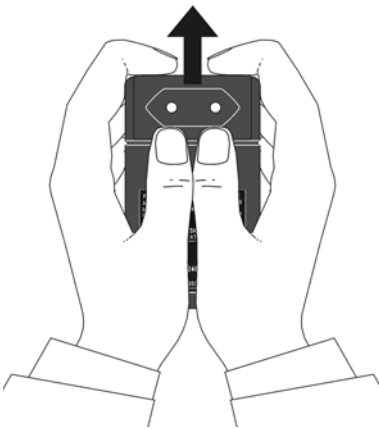

1. Press the plug adapter up. Press strongly to overcome the locking force threshold; a click can be heard.

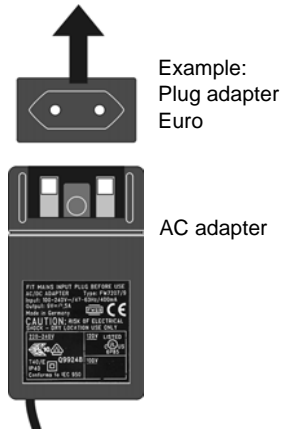

2. Pull the plug adapter up and out of the housing.

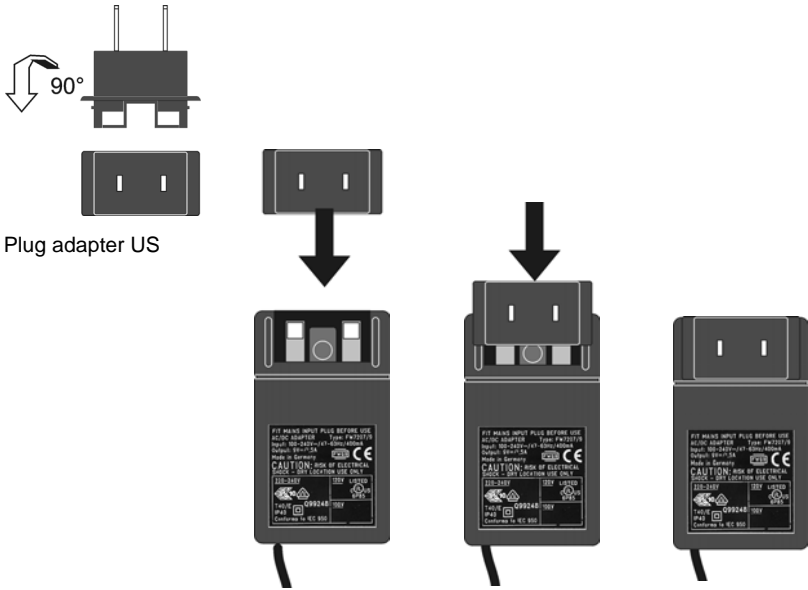

3. Insert the plug adapter. Observe the guide grooves on the side.
4. Press the plug adapter down until it engages (click sound).

5.3 Removing the battery from the instrument

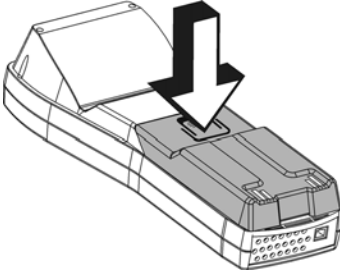

1. Press the release spring until you hear a click sound.

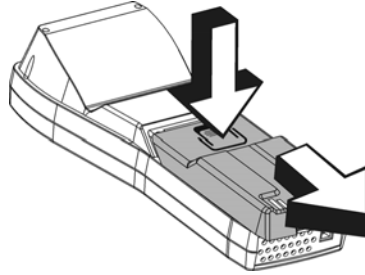

2. Continue to press the release spring and move the battery down.

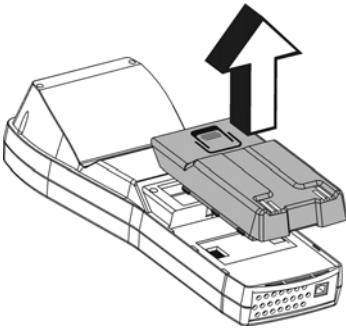

3. Lift the battery off the instrument housing.

5.4 Connecting the battery to the instrument

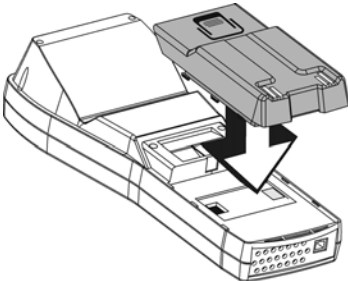



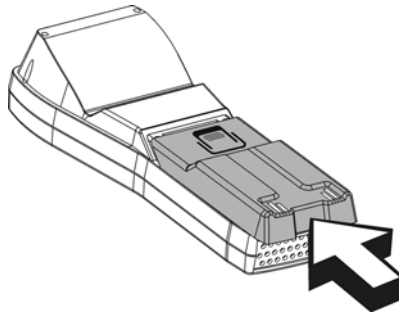

1. Insert the battery in the guide grooves.



2. Push the battery to the front until it engages (click sound).

5.5 Charging the battery using the charging station MPG

The battery charging station may only be used to charge the battery.

- 
This battery charging station may not be used to charge dry batteries (explosion hazard!) or other rechargeable batteries! Improper use can lead to damage of the charging station and to fire!
- 
Use the battery charging station in dry rooms only.
- 
Always pull the plug before cleaning or maintaining the charging station or when it is not in use.
- 
Protect the unit from oil, grease, aggressive detergents and thinners as they may destroy the enclosure.
- 
If the charging station drops, e.g. from a table, the safety of the unit must be checked by a trained professional.

- The design of the battery charging station guarantees the correct terminal position of the inserted battery.
- Always keep the contacts of the battery clean.

Procedure

1. Plug the AC adapter of the charging station into the receptacle.

- 
The AC line voltage must agree with the AC line voltage rating on the serial number plate of the AC power supply!

2. Insert the battery into the charging set.
A lit red LED on the AC adapter indicates that charging is in progress.

- When the main charging process has been completed, the battery charg-

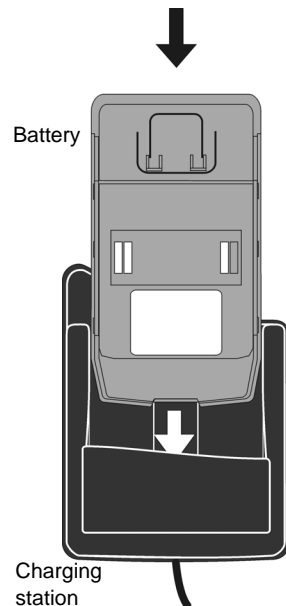

ing set automatically switches to "maintenance mode", which is indicated by the flashing LED.

- If the main charging process cannot be completed within 2.5 h, the battery charging station automatically switches to "maintenance mode".
- An exhausted battery is indicated by the flashing LED after the battery has been inserted. In this operation mode, the battery is charged with a reduced main charging current until it is regenerated, at which point the "regular" main charging mode is switched on.



The battery should not remain in the battery charging station for a long time (several weeks)!

6 Handling of the Probes

6.1 Probe connection

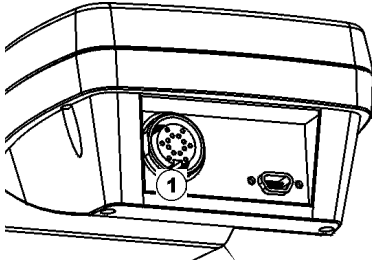

① Connector socket for the probe



Connect the probes only when the instrument is switched off!

To power down the instrument: Press the On/OFF key (turquoise color) on the bottom right side of the operator panel. The display is not lit and no characters are visible.



Instrument and accessories must be protected against static charge!

Electric discharge can damage internal components or delete internally stored data.

Such discharges can occur when connecting a probe to the instrument. The person connecting the probe should always be grounded. It is recommended to store the instrument with the probe connected.

1. Connecting the probe:

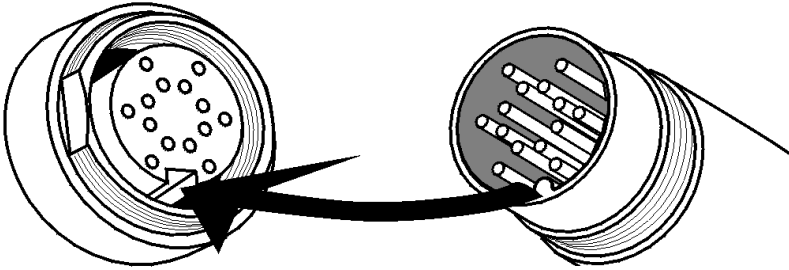

Connector socket of the instrument

Connector plug of the probe



When plugging in the probe, ensure that the keyway of the plug is aligned with the notch of the socket. Do not attempt to plug in the connector in any other way. Doing so will result in a faulty connection between the instrument and the probe, and might damage the pins of the probe plug.

2. Tighten the knurled nut of the probe plug at the instrument socket.

3. Switch the instrument ON.





The instrument recognizes the connected probe model.

- If the open application has not been set up with this probe, the word "Probe" will flash at the upper right edge of the display.





Corresponding to the connected probe, a air value measurement must be performed after powering up the instrument or when opening the application. This is done for measurement reliability.

Hold the probe in the air (Keep a minimum distance to the closest object of 2" (5 cm)) and press the softkey **GET** .

The display of this message, and thus the performance of the system adjustment, can be disabled from the menu function **Measurement options/Air warning**.  166.

6.2 Measurement probe models ESG...

Some probe models can be used for several measurement applications. For example, probe ESG20 is suitable for Paint/Zn/Fe (NC/NF/Fe) and Lacquer/Al (NC/NF) measurements. An application (measurement application memory) may contain the normalization or the corrective calibration for only one or for both measurement applications (test methods) (normalization  44, corrective calibration  50).

The ESG20 probe combines two measurement methods. Thus, this probe can be used to measure the thicknesses of two coatings such as paint and zinc on ferrous substrate materials, and both coating thicknesses can be displayed simultaneously.



The default setting is automatic measurement capture signaled by a beep.  Defining the type of measurement capture Page 160, Enabling/disabling the signal tone Page 157.



Avoid impacting the probe!



Do not allow the probe to float above the surface! Doing so will cause erroneous measurements!



**Do not bend the probe connector cable!
It may lead to line breakage. The bending radius of the cable should be greater 5 cm (2")!**



Please find addition information regarding the measurements from page 75.

- **Always hold the probe at the handle ring.**
Push the handle ring to the specimen surface such that the handle ring rests on the specimen surface.

6.2.1 Measurement on flat specimens

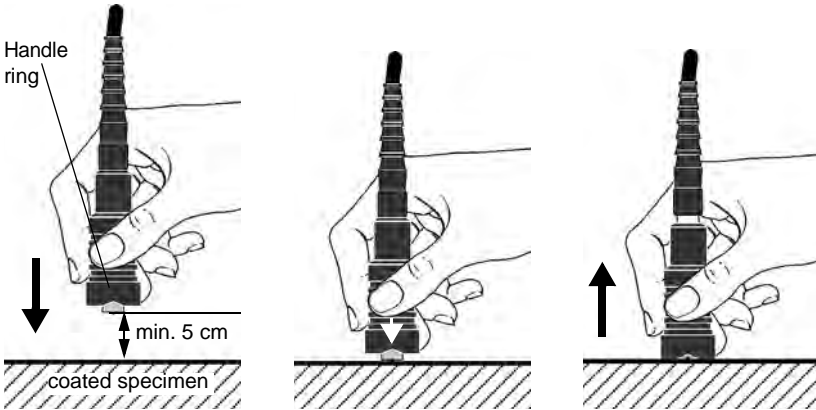

Always place the probe gently and perpendicular to the surface onto the specimen. Lift the probe at least 5 cm (2") off the specimen before making the next measurement.

6.2.2 Measurement on curved specimens

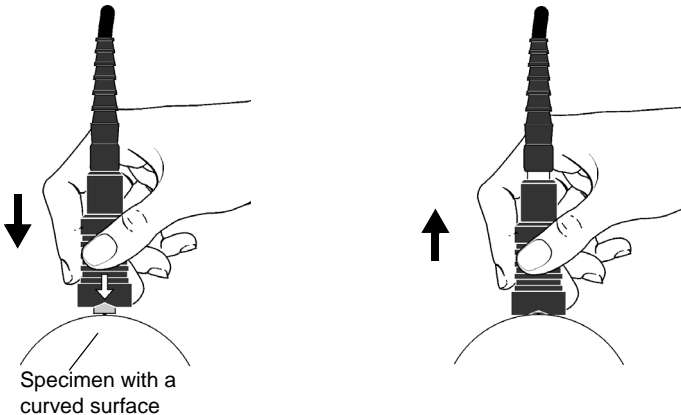

Always place the probe gently and perpendicular to the surface onto the specimen. Lift the probe at least 5 cm (2") off the specimen before making the next measurement.







6.3 Assigning a new probe

If the measurement probe that has been used to set up the open application is defective, a new probe of the same type can be assigned to the open application. Neither the settings nor the measurements of the open applications will be lost. There is no need to set up a new application for the new probe.

The new probe can be assigned to the current application using one of two different (equivalent) methods:

- ZERO key,  39.
- Menu function **Application/Assign New Probe**,  41.



Procedure using the ZERO key

Key sequence/Action	Explanation
1. Connect the new probe to the instrument and switch the instrument ON.	 Probe connection, from page 35.
2. 	Press this key. The display shows the name of the open application and the probe type of the new connected probe.
3. CURR	Assign the new probe only to the currently open application. Or Assign the new probe to all applications that have been set up with the same probe as the currently open application.
ALL	
4.  ,  ,  , 	Assigning the new probe: Press these keys in sequence. Enters the supervisor code.

Key sequence/Action	Explanation
---------------------	-------------

5. A message regarding the probe assignment and a notification to perform a normalization (substrate material or coating material adjustment) will appear.

6. **CONTINUE** Press this softkey.
Switches to the measurement mode of the open application.









 Corresponding to the connected probe, step # 6 may be expanded in the form that an air value measurement must be performed (system adjustment) in order to return to the measurement mode. System adjustment: Hold the probe in the air (Min. distance to the closest object 5 cm (2")) and press the softkey **GET** .

This system adjustment is not applicable if the warning message function has been disabled in the menu function **Meas. options/Air value warning**.  166.



7. We recommend performing a corrective calibration (adjustment of the measurement system to the specimen) for each application with a newly assigned probe prior to the first measurement with the newly assigned probe!

 Please observe the general notes on page 42.

Procedure using the menu function Application/Assign New Probe

- | Key sequence/Action | Explanation |
|---|---|
| 1. Connect the new probe to the instrument and switch the instrument ON. |  Probe connection from page 35. |
| 2.  ,  ,  | Press these keys in sequence in the menu function Application/Assign New Probe . |
| 3.  ,  ,  ,
 | Password protected menu function. Press these keys in sequence. Enters the supervisor code. |
| The display shows the name of the open application and the probe type of the new connected probe. | |
| 4. CURR | Assign the new probe only to the currently open application. |
| | Or |
| ALL | Assign the new probe to all applications that have been set up with the same probe as the currently open application. |
| 5. A message regarding the probe assignment and a notification to perform a normalization (substrate material or coating material adjustment) will appear. | |
| 6. CONTINUE | Press this softkey. Switches to the measurement mode of the open application. |



Key sequence/Action	Explanation
---------------------	-------------

 Corresponding to the connected probe, step # 6 may be expanded in the form that an air value measurement must be performed (system adjustment) in order to return to the measurement mode. System adjustment: Hold the probe in the air (Min. distance to the closest object 5 cm (2")) and press the softkey **GET** .

This system adjustment is not applicable if the warning message function has been disabled in the menu function **Meas. options/Air value warning**.  166.

7. We recommend performing a corrective calibration (adjustment of the measurement system to the specimen) for each application with a newly assigned probe prior to the first measurement with the newly assigned probe!

 If the instrument cannot find the appropriate probe type (e.g., the probe does not have proper contact) or if the wrong probe type is displayed, disconnect and reconnect the new probe and press the softkey **REPEAT**.

 In applications that have been set up with the old probe and that have not yet been assigned the new probe, **Probe**  will flash in the upper right display corner.

 Information regarding, and performance of, a corrective calibration (adjustment of the measurement system to the specimen) from page 50.

7 Compensation of Variables That Influence the Measurements

This chapter is concerned with the correction of systematic influences on the measurement that originate from the properties of the specimen and the measurement probe. As a rule, such influences can be compensated through a so-called normalization or corrective calibration. The corrective calibration with coated standards (specimens with a known coating thickness) facilitates a more precise compensation of the influences.

At the factory, a master calibration has been performed for the measuring system (instrument and probe) using a corresponding master calibration standard set. The purpose of the master calibration is to adjust the measuring system to a base condition. This means, a master characteristic that corresponds to a particular measurement application (substrate material, coating material and coated standards with known coating thicknesses of the predefined probe measuring range,  173) is stored in each probe. The instrument reads this characteristic when the probe is connected. Depending on the deviation of the present measurement application from the one described in the probe, the specified master characteristic can be adapted to the respective properties of the present specimen, or to the measurement application, using a normalization or a corrective calibration.

The three kinds of calibrations are distinguished as follows:

- **Normalization**

Adjustment of the measuring system to the coating material and/or the substrate material (depending on the probe in use).

As a rule, it must be performed after setting up an application.

- **Corrective calibration**

Is necessary when the normalization for the compensation of the influencing variables is not sufficient (e.g., for greater deviations of the material properties versus those taken into account in the master characteristic).

- **Master calibration**

Adjustment of the measuring system to a base condition. Adjustment of

the measuring system to a coating/substrate material combination that has not been pre-defined in a standard manner.

The master calibration fundamentally affects all applications that have been set up with this probe.



For coating thickness measurements, a normalization/calibration should be performed under conditions that are comparable to those at the specimen. Corresponding to the measurement method, various calibration standards are required for the normalization/calibration. Calibration standards are reference parts with a clean and if possible smooth surface. Calibration standards are the most important prerequisites for correct measurements. Thus, they should always be in good condition.

 Building calibration standards see from page 62.



We recommend performing a reference measurement to check the normalization/calibration.



Probes shipped by Fischer are pre-calibrated (master-calibrated).

7.1 Normalization (coating and substrate adjustment)

The normalization adjusts the measuring system to the coating material and/or the substrate material. Thus, it defines the zero point of the master characteristic. The normalization is carried out only for the open application, or all applications linked to it.



The normalization function cannot be called as long as the menu overview is visible on the display.



Description of softkeys beginning on page 10.

Instrument operation beginning on page 15.

Handling of the probes beginning on page 35

Linked applications beginning on page 106.

Required:

- After setting up a new application,
- when changes occur, especially of the geometric properties of the specimen,
- after a new probe has been assigned to the open application.

Coating/substrate material	Influencing variables	Probe
NC/NF/Fe (Paint/Zn/Fe)	<ul style="list-style-type: none">● magnetic permeability of the ferrous substrate material● el. conductivity of the NF coating material	ESG20
NC/NF (Lacquer/Al)	<ul style="list-style-type: none">● el. conductivity of the NF substrate material	ESG20

NF: Non-magnetizable, electrically conducting coatings (non-ferrous metal material)

NC: Insulating materials, electrically non-conducting, non-magnetizable

Fe: Magnetizable material of steel or iron

Al: Aluminum

Zn: Electroplated zinc coating



The above table lists coating/substrate material combinations for which the measuring system is master-calibrated as a standard.

The measuring system must be master-calibrated if other coating/substrate material combinations are present. Please contact your authorized Fischer distributor or Helmut Fischer GmbH Institut für Elektronik und Messtechnik directly for appropriate master calibration standard sets.



With the phase-sensitive eddy-current method used, the reading is dependent on the magnetic permeability and the electrical conductivity, respectively. It is, therefore, necessary that the user produces calibration standards (base, saturation and coated calibration parts) from the in-house production.

7.1.1 Required Materials/Standards (from Own Production)

Standards (from own production) for Paint/Zn/Fe:

- Saturation: Reference part of the metallic coating material (Zn) with a thickness that is greater than the max. measurable thickness.
- BASE: Uncoated specimen or material that corresponds to the uncoated specimen in material properties and geometry.



To measure on base, do not use the supplied NF/Fe plate! It should be used for a function check only!

Standards (from own production) for Lacquer/Al:

- BASE: Uncoated specimen or material that corresponds to the uncoated specimen in material properties (el. conductivity) and geometry.



To measure for BASE, do not use the supplied ISO/NF (ISO = NC) plate! It should be used for a function check only!

The supplied ISO/NF plate can be used only if the material properties (el. conductivity, etc.) of the specimen substrate material agree with those of the supplied plate.



Information on preparing in-house calibration standards can be found beginning on page 62.

7.1.2 Normalization Procedure



When calling the normalization function (ZERO key), the block is closed, or if "automatic block creation" is enabled, the measurements of the still open block will be deleted.



Perform the normalization carefully!

It determines the accuracy for the subsequent measurements. - Please consider that measurements can never be more accurate than the normalization!!





The influence of the electrical conductivity of the coating material must be taken into account when normalizing on **non-ferrous metal coatings** (Zn) and on **non-ferrous metal substrate material**. The electrical conductivity is temperature-dependent, such that the temperature of the standard during normalization must be the same as the temperature of the specimen during the measurement.

The normalization procedure differs depending on the present coating/substrate material combination:

- **Normalization for Paint/Zn/Fe:** perform steps #1 to #9 as described.
- **Normalization for Paint/Al:** perform steps #1 to #6 and #9. Select "NC/NF" in step #2.

	Key sequence / Action	Explanation
1.		Press this key. Calls the normalization function.
2.	,	Selects the present coating/substrate material combination. NC/NF/Fe for e.g. Paint/Zn/Fe NC/NF for e.g. Paint/Al
3.		Confirm/accept selection.

Key sequence / Action	Explanation
4. Hold probe in the air.	The distance to the closest object must be a minimum of 5 cm (2").
5. GET 	Press this softkey. Measures the air value.
6. Paint/Zn/Fe	In general, 5 to 10 measurements are sufficient.
Measurement on BASE.	Phi : Measured phase angle
Perform several measurements with the probe on the base (= substrate material only = uncoated specimen).	Phi . : Mean phase angle
	n : Number of measurements
	S : Standard deviation
Lacquer/Al	In general, 5 to 10 measurements are sufficient.
Measurement on SATURATION.	t.h : Measured coating thickness
Perform several measurements with the probe on the saturation standard (= coating material only).	t.h : Mean value of measured values
	n : Number of measurements
	S : Standard deviation
7. 	Confirm/accept measurements.
8. Measurement on SATURATION.	In general, 5 to 10 measurements are sufficient.
Perform several measurements with the probe on the saturation standard (= coating material only).	Phi : Measured phase angle
	Phi . : Mean phase angle
	n : Number of measurements
	S : Standard deviation

Key sequence / Action	Explanation
------------------------------	--------------------

9.



Ends the normalization; return to the measurement mode of the open application.

Perform another normalization for the second coating / substrate material combination if the application calls for measurements on both Fe and NF substrate materials.

7.2 Corrective calibration (adjustment to the specimen)

The corrective calibration facilitates a more precise adjustment of the master characteristic stored in the probe to the properties (e.g., permeability, conductivity of the materials, geometry) of the specimen. It not only adjusts to the zero point (base) and/or ∞ -value (saturation), but also to at least one coating thickness. The coating thickness is taken from a coated reference part with a known coating thickness, a so-called calibration standard. Materials and shape of the calibration standard must correspond to those of the specimen to be measured. The corrective calibration must be performed using a calibration standard.

In general, the material properties (permeability, electrical conductivity) of the specimen will differ significantly from those taken into account in the master characteristic. We therefore strongly recommend using 2 coated calibration standards for the corrective calibration.

The corrective calibration applies only to the open application, or to all applications linked to the open one and the coating thickness ranges of the used coated standards, respectively. This means, an accurate measurement with great trueness (accuracy) is possible only in this range. A new corrective calibration (possibly in a new and different application) must be performed for measurements outside of this coating thickness range.

Prerequisites

- At least one coated standard (max. 2) must be available for the corrective calibration. The thickness values of the coated standards must be in the range of the coating thickness to be measured.
- **Paint/Zn/Fe:** The influence of the electrical conductivity of the metal coating material (Zn) must be taken into account when performing corrective calibrations on **non-ferrous metal coatings**. The electrical conductivity is temperature-dependent, such that the temperature of the standards during the corrective calibration must be the same as the temperature of the specimens during the measurement.
- **Paint/Al:** The influence of the electrical conductivity of the substrate material (Al) must be taken into account when performing corrective calibrations on **non-ferrous metal substrate material**. The electrical conductivity is temperature-dependent, such that the temperature of the standards during the corrective calibration must be the same as the tem-

perature of the specimens during the measurement.



When calling the corrective calibration function, the block in the open application is closed, or if "automatic block creation" is enabled, the measurements of the still open block will be deleted.



The corrective calibration function cannot be called as long as the menu overview is visible on the display.



Description of softkeys beginning on page 10.
Instrument operation beginning on page 15.
Handling of the probes beginning on page 35.
Linked applications, page 106.

The procedure for the corrective calibration differs depending on the present coating/substrate material combination:

Coating/substrate material	Probe (example)	Page
NC/NF/Fe (Paint/Zn/Fe)	ESG20	52
NC/NF (Lacquer/Al)	ESG20	58

NF: Non-magnetizable, electrically conducting coatings (non-ferrous metal)

NC: Insulating materials, electrically non-conducting, non-magnetizable

Fe: Magnetizable material of steel or iron

Al: Aluminum

Zn: Electroplated zinc coating





The table above lists coating/substrate material combinations for which the measuring system is master-calibrated as a standard (depending on the probe model).

The measuring system must be master-calibrated if other coating/substrate material combinations are present. Please contact your authorized Fischer distributor or Helmut Fischer GmbH + Co.KG directly for appropriate master calibration standard sets.



With the phase-sensitive eddy-current method used, the reading is dependent on the magnetic permeability and the electrical conductivity, respectively. It is, therefore, necessary that the user produces calibration standards (base, saturation and coated calibration parts) from his own production.  62



For measurements on both substrate materials Fe and NF (Al), the application must be adjusted to both measurement applications (paint/Zn/Fe and lacquer/Al)! To this end, perform a corrective calibration for each measurement application (e.g., first run for paint/Zn/Fe  52 and second run for lacquer/Al  58).

For example, for checking the lacquer thickness in car manufacturing.

7.2.1 **Corrective calibration for Paint/Zn/Fe (Paint on non-ferrous metal coating on steel or iron)**



When calling the corrective calibration function (CAL key), the block is closed, or if “automatic block creation” is enabled, the measurements of the still open block will be deleted.

Required materials/standards (from own production):

- Saturation: Reference part, only of the Zn coating material with a thickness that is greater than the max. measurable thickness ($> 150 \mu\text{m}$). Only Zn coating material without lacquer coating. Mark the measurement area on the reference part at the location where it will be on the actual specimen.



Use the supplied Zn saturation part (602-663) for the measurement on saturation only if there is no possibility of setting up a Zn saturation part from the Zn bath in use.

- Base: Uncoated specimen or material that corresponds to the uncoated specimen in material properties and geometry. Mark the measurement

area on the reference part on the location where it will be on the actual specimen.



To measure on BASE, do not use the supplied NF/FE plate! It should be used for a function check only!

- Coated calibration standard(s): Coated part from the production with substrate and coating materials that correspond to those of the specimen. The thickness of the coating material (Zn) should be in the range of the coating thickness to be measured.
- Calibration foils: Plastic foil of known thickness supplied with the probe, or a plastic foil having a thickness within the coating thickness range to be measured.



Information on creating in-house calibration standards can be found beginning on page 62.



The ESG20 probe combines two measurement methods. Thus, this probe can be used to measure the thicknesses of two coatings such as paint and zinc on ferrous substrate materials, and both coating thicknesses can be displayed simultaneously. For this reason, the corrective calibration must be performed for both coating materials (duplex coating system).

Procedure









Perform the corrective calibration carefully!

It determines the accuracy for the subsequent measurements. - Please consider that measurements can never be more accurate than the corrective calibration!!





The influence of the electrical conductivity of the metal coating material must be taken into account when making corrective calibrations on **non-ferrous metal coatings** (Zn). The electrical conductivity is temperature-dependent, such that the temperature of the standard during corrective calibration must be the same as the temperature of the specimen during the measurement.

Key sequence / Action	Explanation
1. 	Press this key. Calls the corrective calibration function .
2.  , 	Selects the present coating/substrate material combination. NC/NF/Fe for e.g. Paint/Zn/Fe
3. 	Confirm/accept selection.
4. Hold probe in the air.	The distance to the closest object must be a minimum of 5 cm (2").
5. 	Press this softkey. Measures the air value.
6. Measurement on BASE. Perform several measurements with the probe on the base (= Fe substrate material only = uncoated specimen).	In general, 5 to 10 measurements are sufficient. Phi : Measured phase angle Phi . : Mean phase angle n : Number of measurements S : Standard deviation
MEM if or DEL CAL if	Discard the measurements. Perform a new measurement series on the standard. Delete the corrective calibration, return to the measurement mode.
7. 	Confirm/accept measurements.

Key sequence / Action	Explanation
<p>8. Measurement on SATURATION.</p> <p>Perform several measurements with the probe on the saturation standard (= NF coating material only (Zn part from production)).</p>	<p>In general, 5 to 10 measurements are sufficient.</p> <p>Phi : Measured phase angle Phi . : Mean phase angle n: Number of measurements Σ: Standard deviation</p>
<p>NEW if or DEL CAL if</p>	<p>Discard the measurements. Perform a new measurement series on the standard.</p> <p>Delete the corrective calibration, return to the measurement mode.</p>
<p>9. </p>	<p>Confirm/accept measurements.</p>

Adjustment of the Duplex coating system

Adjustment of the paint coating





<p>10. IMP.STD</p>	<p>Opens the display page for entering the nominal value in the respective unit of measurement of the 1st standard = calibration foil.</p>
<p>11.  ... </p>	<p>Entry of the foil value in the respective unit of measurement.</p>
<p>12. </p>	<p>Accept the entry and exit the entry template.</p>

Key sequence / Action Explanation

13. Place the calibration foil on the uncoated specimen. **Std. 1** = first calibration foil.
14. Perform several measurements with the probe on the calibration foil. In general, 5 to 10 measurements are sufficient
 t_h : Measured coating thickness
 $\overline{t_h}$: Mean value of the measured values
 n : Number of measurements
 s : Standard deviation
15.  Confirm/accept measurements.
- or **HEH** if Discard the measurements. Perform a new measurement series on the standard.
16. Measurement on the second calibration foil If desired, the adjustment to the measurement application can be performed with a second calibration foil. To do this, repeat steps 10 to 15.

Adjustment of the Zn coating (NF/FE without paint!)

17. Perform several measurements with the probe on the standard/reference part (= coated part from the production). In general, 5 to 10 measurements are sufficient
 t_h : Measured coating thickness
 $\overline{t_h}$: Mean value of the measured values
 n : Number of measurements
 s : Standard deviation

Key sequence / Action	Explanation
18. IMP.STD	The displayed standard thickness does not correspond to the thickness of the standard: Opens the display page for entering the nominal value in the respective unit of measurement of the 1 st standard/reference part (coated Zn part from the production).
19.  ... 	Entry of the standard value in the respective unit of measurement.
20. 	Accept the entry and exit the entry template.
21. 	Confirm/accept measurements.
or MEH if	Discard the measurements. Perform a new measurement series on the standard.
22. Measurement on the second standard	If desired, the adjustment to the measurement application can be performed with a second standard/reference part. To do this, repeat step 17. and if desired steps 18. to 20. Continue with step 23.
23. 	Ends the corrective calibration; return to the measurement mode of the open application.

7.2.2 Corrective calibration for Lacquer/Al (electrically non-conductive coating on non-ferrous metal substrate)



When calling the corrective calibration function (CAL key), the block is closed, or if "automatic block creation" is enabled, the measurements of the still open block will be deleted.

Required materials/standards (from own production):

- BASE: Uncoated specimen or material that corresponds to the uncoated specimen in material properties (el. conductivity) and geometry.



To measure for BASE, do not use the supplied ISO/NF plate (ISO = NC)! It should be used for a function check only!

The supplied ISO/NF plate can be used only if the material properties (el. conductivity, etc.) of the specimen coating material agree with those of the supplied plate.

- Calibration foils: Plastic foil of known thickness supplied with the probe, or a plastic foil having a thickness within the coating thickness range to be measured.



Information on creating in-house calibration standards can be found beginning on page 62.

Procedure













Perform the corrective calibration carefully!

It determines the accuracy for the subsequent measurements. - Please consider that measurements can never be more accurate than the corrective calibration!!



The influence of the electrical conductivity of the coating material must be taken into account when making corrective calibrations on **non-ferrous metal substrate material** (Al). The electrical conductivity is temperature-dependent, such that the temperature of the standard during normalization must be the same as the temperature of the specimen during the measurement.

Key sequence / Action	Explanation
1. 	Press this key. Calls the corrective calibration function .
2.  , 	Selects the present coating/substrate material combination. NC/NF for e.g. lacquer/Al
3. 	Confirm/accept selection.
4. Hold probe in the air.	The distance to the closest object must be a minimum of 5 cm (2").
5. 	Press this softkey. Measures the air value.
6. Measurement on BASE. Perform several measurements with the probe on the base (= substrate material only = uncoated specimen = only Al).	In general, 5 to 10 measurements are sufficient. t_h : Measured coating thickness $\overline{t_h}$: Mean value of the measured values n : Number of measurements s : Standard deviation
MEH if or DEL CAL if	Discard the measurements. Perform a new measurement series on the standard. Delete the corrective calibration, return to the measurement mode.
7. 	Confirm/accept measurements.

Key sequence / Action	Explanation
8. IMP.STD	Opens the display page for entering the nominal value in the respective unit of measurement of the 1 st calibration foil.
9.  ... 	Entry of the foil value in the respective unit of measurement.
10. 	Accept the entry and exit the entry template.
11. Place the calibration foil on the uncoated specimen.	Std. 1 = first calibration foil.
12. Perform several measurements with the probe on the calibration foil (= uncoated specimen with calibration foil).	<p>In general, 5 to 10 measurements are sufficient</p> <p>t_h: Measured coating thickness</p> <p>$\overline{t_h}$: Mean value of the measured values</p> <p>n: Number of measurements</p> <p>s: Standard deviation</p>
13. 	Confirm/accept measurements.
or MEH if	Discard the measurements. Perform a new measurement series on the standard.
14. Measurement on the second standard	If desired, the adjustment to the measurement application can be performed with a second standard/reference part. To do this, repeat steps 8 to 12. Continue with step 15.
15. 	Ends the corrective calibration; return to the measurement mode of the open application.

7.3 Deleting the corrective calibration

The corrective calibration (adjustment of the measuring system to the specimen) of the open application will be deleted or of the applications linked to one another. The master characteristic stored in the probe will again apply without restrictions.







Description of the softkeys beginning on page 10.

Instrument operation beginning on page 15.

Menu function **Appl. Management/Link Applications**, page 106.

Procedure

- | Key sequence / Action | Explanation |
|--|---|
| 1.  | Press this key.
Calls the corrective calibration function . |
| 2.  ,  | Select the coating/substrate material combination that has been used for the corrective calibration of the application
NC/NF/Fe for e.g. Paint/Zn/Fe
NC/NF for e.g. lacquer/Al |
| 3.  | Confirm/accept selection. |
| 4. Hold probe in the air. | The distance to the closest object must be a minimum of 5 cm (2"). |
| 5. GET  | Press this softkey.
Measures the air value. |
| 6. DEL CAL | Deletes the corrective calibration.
Switch to the measurement mode of the open application.
Repeat the procedure to delete the corrective calibration for both coating/substrate material combinations. |

7.4 Preparing in-house calibration standards

The measurement signal is dependent on the coating thickness and, depending on the probe type, also on the electrical conductivity and/or the permeability of the coating and substrate materials. A calibration standard must be prepared to take these material properties into account. Using this calibration standard in a corrective calibration, the measuring system can then be adjusted to the properties of the specimen.

A specimen is taken from the production to prepare a calibration standard. For zinc measurements, parts from a bath with the same type of electrolyte (acidic, alkaline cyanide or cyanide-free), because the conductivity of the zinc coating is defined by the electrolyte.

The specimen must exhibit a uniform coating thickness distribution in order to assign a coating thickness value to this specimen. Measurements are made at several locations of the specimen to determine the coating thickness distribution. Because only the coating thickness fluctuations are of interest and not the absolute value, even an instrument (PMP10 DUPLEX) that has not yet undergone final calibration can be used. The coating thickness distribution can now be determined based on the measurement fluctuations (standard deviation). Once a specimen with a uniform coating thickness distribution (low standard deviation) has been found from the production, the (absolute) coating thicknesses are then measured using a different measuring method (e.g., coulometric or x-ray fluorescence method). Based on the uniform coating thickness distribution, the mean value from these measurements specifies the coating thickness value for the specimen. By assigning a coating thickness value, the specimen becomes a calibration standard. A measurement spot with the assigned thickness value, and where the measurements will take place during the corrective calibration, must be marked on the calibration standard.

8 Master Calibration

A master characteristic forms the basis for converting the probe output signals into measurement data (coating thickness values).



The master calibration irrevocably changes the master characteristic in the probe!

During the master calibration, a new master characteristic is established for a certain probe from the following data: zero point, ∞ -value (saturation) and several coating thickness values. For this reason, calibration standards must be dependable and the calibration must be performed meticulously!

Procedure

The procedure for the master calibration differs corresponding to the respective coating/substrate material combination:

Coating/Substrate material	Probe (example)	Page
NC/NF/Fe (e.g. Paint/Zn/Fe)	ESG20	63
NC/NF (e.g. Lacquer/Al)	ESG20	71

NF: Non-magnetizable, electrically conducting materials (non-ferrous metal material)

NC: Insulating materials, electrically non-conducting, non-magnetizable

Fe: Magnetizable material of steel or iron

Al: Aluminum

Zn: Electroplated zinc coating



Please contact your authorized distributor or Helmut Fischer GmbH Institut für Elektronik und Messtechnik directly for appropriate master calibration standard sets.



Information on preparing in-house calibration standards can be found beginning on page 62.

8.1 Master calibration for Paint/Zn/Fe

(paint and non-ferrous metal coatings on steel or iron)

As a standard, the probes (ESG20) supplied by Fischer are master-calibrated

for the coating/substrate material combination Paint/Zn/Fe (electroplated zinc coating). A master re-calibration may be required in certain service instances. A new master calibration must be performed for a coating if the measurement is to be made on a coating other than electroplated zinc.

The master calibration is performed for the connected probe and probe frequency that is displayed in the measuring mode of the open application.



To avoid erroneous measurements, the corrective calibrations (adjustment of the measuring system to the specimen) will be deleted during the master calibration in those applications that have been set up with the probe for which the master calibration is now being performed.



The ESG20 probe combines two measurement systems. Thus, this probe can be used to measure the thicknesses of two coatings such as paint and zinc on ferrous substrate materials, and both coating thicknesses can be displayed simultaneously. During the master calibration, these two measuring systems (MAGNA, PHASE) must be adjusted separately.

Prerequisites

- 10 standards (BASE (= uncoated specimen = substrate material), saturation (= NF material only = metal coating material only), 4 coated standards and 4 calibration foils) must be available for the master calibration.



The master calibration should be performed at an ambient temperature of +20°C (68°F). The standards should be at ambient temperature as well.



Perform the master calibration carefully, it determines the accuracy for the subsequent measurements. - Please consider that measurements can never be more accurate than the master calibration itself!



A new master calibration irrevocably overwrites the old master calibration!!



Please contact your authorized distributor or Helmut Fischer GmbH Institut für Elektronik und Messtechnik directly for appropriate master calibration standard sets.













Information on preparing in-house calibration standards can be found beginning on page 62.





Description of the softkeys beginning on page 10.
Instrument operation beginning on page 15.
Probe handling beginning on page 35.

For security reasons, the menu function **Calibration/Master Calibration** is protected from unauthorized access by a password, the supervisor code.

Procedure

- | | Key sequence / Action | Explanation |
|----|--|---|
| 1. |  ,  ,  | Press this key sequence.
Calls the menu function Calibration/Master Calibration . |
| 2. |  ,  ,  ,
 | Password-protected menu function.
The supervisor code must be entered to open the menu function. |
| 3. |  ,  | Selects the present coating/substrate material combination.
NC/NF/Fe for e.g. Paint/Zn/Fe |
| 4. |  | Confirm/accept selection. |
| 5. | Hold probe in the air. | The distance to the closest object must be a minimum of 5 cm (2"). |

Key sequence / Action	Explanation
6. GET 	Press this softkey. Measures the air value.
7. Measurement on BASE. Perform several measurements with the probe on the base (= substrate material only = uncoated specimen).	In general, 5 to 10 measurements are sufficient. Phi : Measured phase angle Phi . : Mean phase angle n : Number of measurements Σ : Standard deviation
8.  or NEH	Confirm/accept measurements. Discard the measurements. Perform a new measurement series on the standard.
9. Measurement on SATURATION. Perform several measurements with the probe on the saturation standard (= coating material only (Zn)).	In general, 5 to 10 measurements are sufficient. Phi : Phase angle Phi . : Mean phase angle n : Number of measurements Σ : Standard deviation
10.  or NEH	Confirm/accept measurements. Discard the measurements. Perform a new measurement series on the standard.

Key sequence / Action Explanation

The two measuring systems of the probe must be adjusted separately.

MAGNA:

For the adjustment to paint coatings, see steps beginning at 11.

PHASE:

For the adjustment to metallic coatings, see steps beginning at 21.

MAGNA: Adjustment to the paint coating

11. **MAGNA** Press the softkey to adjust the "MAGNA" measuring system to the new measurement application.



12. **IMP.STD** Opens the display page for entering the nominal value in the respective unit of measurement of the 1st (xth) calibration foil.

13.  Enter the foil value in the respective unit of measurement.

14.  Confirms the entry and exits the entry template.





15. Place the calibration foil on the uncoated specimen (BASE). **Std. 1** = first calibration foil.

16. Measure several times on the calibration foil. In general, 5 to 10 measurements are sufficient
 \bar{x}_n : Normalized countrate
 \bar{x}_n : Mean normalized countrate
 n : Number of measurements
 s : Standard deviation

Key sequence / Action	Explanation
17.  or or NEW or INTERU.	Confirm/accept measurements. Discard the measurements. Perform a new measurement series on the standard. The four calibration foils must be within the displayed intervals. The reading of the now measured standard appears under Measured : . Close the display with RETURN .
18. Measure on the additional calibration foils.	For the measurements on the additional calibration foils repeat steps 12. to 17. Continue with step 19.
19. 	At the end, the corrective calibrations that have been set up with the probe for which the master calibration has been performed will be deleted. The display shows a corresponding message.
20. CONTINUE	Continue with the next step, the adjustment of the second measuring system (PHASE).

PHASE: Adjustment to the metallic coating

21. PHASE	Press the softkey to adjust the "PHASE" measuring system to the new measurement application.
22. IMP.STD	Opens the display page for entering the nominal value in the respective unit of measurement of the 1 st (x th) coated standard.

	Key sequence / Action	Explanation
23.	 ... 	Enter the standard value in the respective unit of measurement.
24.		Confirms the entry and exits the entry template.
25.	Measure several times on the coated standard.	In general, 5 to 10 measurements are sufficient \bar{x}_n : Normalized countrate \bar{x}_n : Mean normalized countrate n : Number of measurements s : Standard deviation
26.	 or or HEH or INTERU.	Confirm/accept measurements. Discard the measurements. Perform a new measurement series on the standard. The four calibration foils must be within the displayed intervals. The reading of the now measured standard appears under Measured: . Close the display with RETURN.
27.	Measure on the additional coated standards.	For the measurements on the additional coated standards repeat steps 22. to 26. Continue with step 28.
28.		At the end the message again, that the corrective calibrations that have been set up with the probe for which the master calibration has been performed will be deleted.

Key sequence / Action	Explanation
29. CONTINUE	Closes the message in the display.
30. END	Ends the master calibration. Return to the measurement mode of the open application.

8.2 Master calibration for Lacquer/Al

(electrically non-conducting coating on non-ferrous metal substrate)

As a standard, the probes (ESG20) supplied by Fischer are master-calibrated for the coating/substrate material combination Paint/Al. A master re-calibration may be required in certain service instances. A new master calibration must be performed for a substrate material if the measurement is to be made on a substrate material other than Al.

The master calibration is performed for the connected probe and the probe frequency that is displayed in the measuring mode of the open application.



To avoid erroneous measurements, the corrective calibrations (adjustment of the measuring system to the specimen) will be deleted during the master calibration in those applications that have been set up with the probe for which the master calibration is now being performed.

Prerequisites

- 5 standards (BASE (= uncoated specimen, substrate material) and 4 calibration foils) must be available for the master calibration.



The master calibration should be performed at an ambient temperature of +20°C (68°F). The standards should be at ambient temperature as well.



Perform the master calibration carefully, it determines the accuracy for the subsequent measurements. - Please consider that measurements can never be more accurate than the master calibration itself!



A new master calibration irrevocably overwrites the old master calibration!!



Please contact your authorized distributor or Helmut Fischer GmbH Institut für Elektronik und Messtechnik directly for appropriate master calibration standard sets.













Information on preparing in-house calibration standards can be found beginning on page 62.







- Description of the softkeys beginning on page ?.
- Instrument operation beginning on page ?.
- Probe handling beginning on page ?.

For security reasons, the menu function **Calibration/Master Calibration** is protected from unauthorized access by a password, the supervisor code.

Procedure







	Key sequence / Action	Explanation
1.	 ,  , 	Press this key sequence. Calls the menu function Calibration/Master Calibration .
2.	 ,  ,  , 	Password-protected menu function. The supervisor code must be entered to open the menu function.
3.	 , 	Selects the present coating/substrate material combination. NC/NF for e.g. Lacquer/Al
4.		Confirm/accept selection.
5.	Hold probe in the air.	The distance to the closest object must be a minimum of 5 cm (2").
6.		Press this softkey. Measures the air value.

Key sequence / Action	Explanation
7. Measurement on BASE. Perform several measurements with the probe on the base (= substrate material only = uncoated specimen).	In general, 5 to 10 measurements are sufficient. t_h : Measured coating thickness $\overline{t_h}$: Mean value of the measured values n : Number of measurements s : Standard deviation
8.  or	Confirm/accept measurements.
MEH	Discard the measurements. Perform a new measurement series on the standard.
9. IMP.STD	Opens the display page for entering the nominal value in the respective unit of measurement of the 1 st (x th) calibration foil.
10.  ... 	Enter the foil value in the respective unit of measurement.
11. 	Confirms the entry and exits the entry template.
12. Place the calibration foil on the uncoated specimen (BASE).	Std. 1 = first calibration foil.

Key sequence / Action	Explanation
13. Measure several times on the calibration foil.	<p>In general, 5 to 10 measurements are sufficient</p> <p>t_h: Measured coating thickness</p> <p>$\overline{t_h}$: Mean value of the measured values</p> <p>n: Number of measurements</p> <p>s: Standard deviation</p>
14.  or or NEW or INTERU.	<p>Confirm/accept measurements.</p> <p>Discard the measurements. Perform a new measurement series on the standard.</p> <p>The four coated standards must be within the displayed intervals. The reading of the now measured standard appears under Measured: .</p> <p>Close the display with RETURN.</p>
15. Measure on the additional calibration foils.	<p>For the measurements on the additional standards repeat steps 9. to 14. Continue with step 16.</p> <p>At the end, the corrective calibrations that have been set up with the probe for which the master calibration has been performed will be deleted. The display shows a corresponding message.</p>
16. CONTINUE	<p>Ends the master calibration. Return to the measurement mode of the open application.</p>

9 Measurement

9.1 The quick path to measurements

1. Connect the probe to the instrument,  35, and turn the instrument on,  15.
2. Set up the application in the instrument,  95, or calling an application,  18.
3. Take influencing variables into account by adjusting the measuring system to the specimen.  43.
4. Perform the measurement.  77; handling of the probe beginning on page 35.
5. View/print the evaluation (statistical characteristic quantities, graphical display of the characteristic quantities).  82.

9.2 Influencing variables



The default pre-calibration (master calibration) of the measuring system (probe ESG20 and measuring instrument) is for measurements of paint/zinc coatings on iron/steel and for measurements of lacquer coatings on aluminum.

The measuring system must receive a new master calibration for other coating/substrate material calibrations. Please contact your authorized Fischer distributor or Helmut Fischer GmbH Institut für Elektronik und Messtechnik directly for appropriate master calibration standard sets.

9.2.1 Measurement of duplex coatings on steel or iron

The electrical conductivity of the metallic coating material and the magnetic permeability of the ferrous substrate material influence the measurements of duplex coatings. A normalization, or a corrective calibration (adjustment of

the measuring system to the specimen) using standards from one's own production, is, therefore, absolutely necessary. The electrical conductivity, in turn, is influenced by the temperature, such that the specimens must exhibit a similar temperature during the measurement and during the normalization/corrective calibration.

Aside from galvanically deposited zinc coatings, hot dip galvanized coatings can be measured only if there are no pronounced diffusion zones between zinc and steel.

To measure zinc alloy coatings such as ZnNi or ZnFe, the measuring system must be adjusted using a corrective calibration (with two standards) or even a master calibration.

9.2.2 Measurement of lacquer coatings on metallic non-ferrous substrate materials

The electrical conductivity of the substrate material influences measurements on metallic non-ferrous substrate materials. A normalization or a corrective calibration (adjustment of the measuring system to the specimen) using standards from one's own production, is, therefore, absolutely necessary. The electrical conductivity, in turn, is influenced by the temperature, such that the specimens must exhibit a similar temperature during the measurement and during the normalization/corrective calibration.

9.2.3 Measurements on both ferrous and non-ferrous substrate materials

With the PHASCOPE® PMP10 DUPLEX and the ESG20 probe, measurements can be made without problems on both Fe substrate materials and NF substrate materials (Al) in one application. This is possible because the ESG20 probe combines two measurement methods and the measuring system recognizes the substrate material automatically. Thus, the appropriate measurement method is used automatically for a measurement. However, this requires that a normalization or corrective calibration has been performed for each measurement method (paint/Zn/Fe and lacquer/Al). Thus, the influencing variables of both previous sections must be taken into account. For example, checking the lacquer thickness in car manufacturing requires measurements on various substrate materials .

9.3 Making a measurement

Measurements on flat or curved surfaces: Place the probe vertically on the surface of the specimen,  37.

Following the measurement accept, i.e., after the reading appears on the display, lift the probe off the surface. After a few seconds, the instrument is ready to measure again.



Corresponding to the connected probe, an air value measurement may be required when making measurements. This is done for measurement reliability.

Hold the probe in the air (at least 2" (5 cm) distance to the closest object) and press the softkey **GET** .

The appearance of this message and thus the performance of the system adjustment can be disabled using the menu function **Measurement Options/Air value warning**.  166.

9.3.1 The following should be observed when performing measurements:

- The measurement should be performed within a reference area.
- To avoid erroneous measurements, do not allow the probe to float above the specimen!
- When lifting the probe off, remove it at least 5 cm (2 ") from the specimen!
- When making measurements in an existing application, the same probe that was used to set up the application must be used to make the measurements. Otherwise **PROBE** will flash in the upper right display corner and it will not be possible to make a measurement.

9.3.2 Measurement accept

The factory default setting is automatic measurement accept, that is, the measurements are accepted automatically after placing the probe on the specimen, additionally, an acoustic signal will sound.



Editing the measurement accept function, page 160.
 Disabling the acoustic signal for measurement accept, page 157.

9.3.3 Acoustic signals after measurement accept

In addition to the acoustic measurement accept signal, the acoustic signals listed in the following table may sound as well. These signals may sound in succession.

Signal	Meaning
1 x short beep	Reading has violated the lower specification limit.
2 x short beeps	Reading has violated the upper specification limit.
2 x long beeps	Reading has been identified as an outlier.



Setting the specification limits, page 116.
 Enable the outlier control, page 113.

9.3.4 Measurement identification

Measurements that fall outside the set limits or control mechanisms are identified on the display by symbols to the left of the measurement value.

Symbol in front of the measurement	Meaning
▼	Reading has violated the lower specification limit.
▲	Reading has violated the upper specification limit.
!	Reading has been identified as an outlier.
🔑	Last measurement of the block.

9.3.5 Creating a block

The measurements of an application can be separated into so-called blocks. A block contains a certain number of measurements. Blocks are always created during the measurement - automatically or manually.

Automatic block creation

For certain evaluation formats (sum frequency chart, histogram, etc.), measurements with fixed specified block sizes are mandatory. A fixed block size can be entered in the menu function **Application/Modify Application**.

Example: Automatic block creation is enabled and set to 5 measurements per block. Measurements are made continuously. After every 5 measurements, the instrument automatically closes a block and marks the end on the display with a key as a block separator character.



Enabling automatic block creation and setting the block size, page 117. Evaluation, beginning on page 82.



With "continuous display" enabled, automatic block creation is deactivated.

Manual block creation

A block can be closed after any number of measurements.

Procedure

Key sequence / Action	Explanation
1. BLOCK	Calling the Block Result Menu is carried out from the measurement mode.
2. CLOSE	Closes a block. The instrument automatically returns to the measurement mode. The current reading receives a key symbol for identification purposes.

9.4 Measurement with "continuous" display

Use this menu function to disable automatic display saving. The measurement is not accepted when the probe is placed on the specimen but when an "Ext. Start" is actuated (key , using a push-button connected to the instrument or via interface commands).



- Setting the measurement accept, page 160.
- Setting the data transfer formats, beginning on page 138.
- Data transfer, beginning on page 144.
- Enable/Disable air value warning, page 166.

When making measurements with the "continuous" display mode, the measured readings are displayed continuously by scanning the specimen surface. However, the readings are not saved automatically.







When the parameter **i Individ. Values** is enabled, it will be deactivated automatically when enabling the continuous display menu function. The parameter will be reactivated when the continuous display menu function is disabled.

Procedure



The parameter **Ext. Start** must be enabled from the menu function **Measurement Options/Accept Measurement**.

Key sequence / Action	Explanation
1.  ,  , 	Press these keys in succession. Enables "continuous" display = calls the menu function Measurement Options/Free Display Mode .
2. Place the probe on the specimen and move it across the specimen surface.	The display continuously shows the measured readings. - No automatic storage of the readings.

- | Key sequence / Action | Explanation |
|---|---|
| 3.  or
Press the pushbutton connected to the instrument or
Send the commands "G0", "ES", "EN" or "ESC?" via the RS232 interface. | Accepts the measurement. |
| 4. CONT. OFF | Disables the "continuous" display mode from the measurement mode. |

9.5 Measurement with external start enabled

If automatic measurement accept is not desired after placing the probe on the specimen, the measurement accept can be triggered manually by the following means:

- Pressing the key  .
 This is only possible if the parameter **Ext. Start** is enabled from the menu function **Measurement Options/Accept Measurement!**
- Sending the commands "G0", "ES", "EN" or "ESC?" via the RS232 interface.
 This is only possible if the appropriate data transfer formats are set from the menu function **System options/RS232 Configuration**.



Setting the measurement accept, page 160.

Setting the data transfer format, beginning on page 138.

Data transfer, beginning on page 144.

10 Evaluation

The instrument saves the user from having to do the sometimes complicated and extensive mathematical computations for the statistical evaluation of the measurement data. The evaluation is performed separately for each block, or across a selection of blocks.

The block result of the last block (open or already closed), but also of a block set up earlier can be viewed or printed from the **Block Result Menu**.

The statistical characteristic data can be viewed and printed from the **Evaluation Menu**. Presentation modes such as sum frequency chart (probability chart) and histogram are part of the standard instrument configuration and can be called by using a softkey from the evaluation menu.

Evaluation of one block, page 83.

Evaluation across a number of blocks, page 84 and page 93.

Statistical characteristics (block, final result), beginning on page 87.

Graphical display format sum frequency chart, page 91.

Graphical display format histogram, page 92.

Evaluation in the simple display and operating mode, page 93.

The second menu page of the evaluation menu contains softkeys for data transfer, for example, to a computer, and for printout.



Printing of measurement data, beginning on page 127.

Data transfer via RS232 interface, beginning on page 138.

10.1 Evaluation of one block

An evaluation across the values measured since the last closed block is carried out automatically after each measurement accept. The evaluation of the open block and of all closed blocks can be viewed and printed from the Block Result menu.



For time reference, the current date and time are stored whenever a block is closed (manually or automatically).



The evaluation of the statistical characteristic data will be displayed as shown in the table "Block result" on page 87.





With applications for duplex measurements, the values of both coatings are displayed: Index "1" indicates the NC coating (e.g., paint) and Index "2" indicates the NF coating (e.g., Zn).



Printer connection and settings beginning on page 127.
Description of the softkey beginning on page 10.
Instrument operation beginning on page 15.

Procedure

Key sequence / Action	Explanation
1. BLOCK	Calling the block result menu is carried out from the measuring mode.
2.  , 	Select the desired block. The respective evaluation for the selected block is displayed directly.
3. PAGE PRINT	To scroll to the next display page to display additional results. and/or To print the displayed block result. The printer must be connected to the instrument and must be ON.

	Key sequence / Action	Explanation
4.	CLOSE	Exiting the Block Result Menu: To close a block upon exiting the menu.
	or CONTINUE	To exit the menu (without closing a block manually).

10.2 Evaluation across several blocks

The evaluation of one, of all or across a number of successive blocks can be performed from the evaluation menu. For example, from block number 3 to block number 7. In this case, the evaluation is across 5 blocks.



In **Applications without automatic block creation**, a block can be closed automatically by calling the evaluation menu (softkey

EVALUATE)!!



The current date and time are stored whenever a block is closed (manually or automatically).



If **automatic block creation is enabled**, evaluation of the statistic characteristic data will be displayed as shown in the table "Final result" on page 88.



If **automatic block creation is disabled**, the evaluation of the statistic characteristic data will be displayed as shown in the table "Final result" on page 90. In this case, the selected (manually created) blocks will be treated as one single block for the evaluation.







With applications for duplex measurements, the values of both coatings are displayed: Index "1" indicates the NC coating (e.g. paint, lacquer) and Index "2" indicates the NF coating (e.g., Zn).



- Description of the softkeys beginning on page 10.
- Instrument operation beginning on page 15.
- Printer connection and settings beginning on page 127.
- Data transfer via RS232 interface beginning on page 138.

Procedure

Key sequence / Action	Explanation
1. EVALUATE	Calling the evaluation menu is carried out from the measuring mode.
2.  ...  	Enter the numbers for the first and the last block to be included in the evaluation. Moves the cursor to the next entry box.
3. PAGE	Navigation in the Evaluation Menu: Scrolls to the next display page to display the softkeys for data transfer via RS232 or to print.
PRINT	Prints the result corresponding to the settings in the menu function Output/Output to Printer . The printer must be connected to the instrument and must be ON.
RS232	Transfers the result via the RS232 interface corresponding to the settings in the menu function Output/Output To RS232 .
STAT.	Calls the statistical characteristic data
	and/or
E	Calls the sum frequency chart This is possible only if at least 5 measurements are present.
	and/or
HISTOGRAM	Calls the histogram; possible only from the sum frequency chart. This is possible only if at least 30 measurements are present.

Key sequence / Action	Explanation
1. , 2.	<p>Navigation</p> <p>Display of the results of duplex measurements for each coating:</p> <p>1. : Results of the NC coating (paint)</p> <p>2. : Results of the NF coating (Zn)</p>
PAGE	Scrolls to the next display page to display additional results.
PRINT	Prints the displayed result. The printer must be connected to the instrument and must be ON.
RETURN	Scrolls back to the evaluation menu.
<p>4.</p> 	<p>Exits the Evaluation Menu.</p> <p>Switch to the measurement mode of the current application.</p>

10.3 Statistical characteristic data

The instrument calculates the following characteristic data:

10.3.1 Block result

Evaluation of the measurements of one single block.



For a description of the statistical terms as well as the formulas used see the Glossary.

Calling the Block Result menu: **ELOCK** from the measurement mode.

Parameter	Description
\bar{th} (in the printout: th.)	Mean value of the single readings = block mean value. Readings of the duplex measurements: "1" indicates the results of the NC coating, "2" indicates the results of the NF coating.
s	Standard deviation. The standard deviation is a measure of the deviations of the single readings of a block from their common mean value.
V	Coefficient of variation [%]. Deviation of a measurement series (block) in percent.
n	Number of single readings per block.
R	Range. Difference between the maximum and the minimum reading of the block.
min.	Lowest reading of the block.
max.	Highest reading of the block.
* Values < LSL	Number of readings (in numbers and percent) that fall below the lower specification limit with a display of the set lower specification limit.
* Values > USL	Number of readings (in numbers and percent) that exceed the upper specification limit with a display of the set upper specification limit.

* Characteristic data will be printed only (do not appear on the display) when specification limit monitoring is enabled.

10.3.2 Final result

for an application with automatic block creation (fixed block size enabled)



For a description of the statistical terms as well as the formulas used see the Glossary.

Calling: **EVALUATE** and **STAT** as well as **I.** or **Z.** for the results from the measurement for the NC or the NF coating.

Parameter	Description
th..	Mean value of the block mean values.
$\hat{\sigma}$	Estimate for the standard deviation σ of the base total.
R.	Mean range of the block ranges.
nGr	Number of blocks that are taken into account for the evaluation.
min.	Lowest block mean value.
max.	Highest block mean value.
** LSL	Lower specification limit setting.
** USL	Upper specification limit setting.
** n<LS	Number of block mean values (in numbers and percent) that are below the lower specification limit.
** n>US	Number of block mean values (in numbers and percent) that are above the upper specification limit.
** Cp	Capability factor.
** Cpk	Capability factor.
*sa	Deviations of the block mean values corrected in relation to the deviations of the single readings.  sa is calculated by the instrument only when the deviations of the block mean values cannot be attributed to the deviations within the blocks, as determined by analysis of variance methods.

Parameter	Description
* ni	Block size (group size), number of single readings per block.
* \hat{V}	Estimated value for the deviation of a test series in percent.
* Confid. interval	<p>With a certain probability, the presumed "true" value of the measurement parameter lies within an interval (dual-sided confidence interval) around the measured mean value of a measurement series.</p> <p> Calculated and printed only when the deviations of the block mean values can be attributed to the deviations within the blocks, as determined by analysis of variance methods.</p>

* Values appear only on the printout; they are not shown on the display.

** Values are shown only if limit monitoring is enabled.

10.3.3 Final result

for an application with manual block creation (automatic block creation is disabled)



For a description of the statistical terms as well as the formulas used see the Glossary.

Calling: **EVALUATE** and **STAT** as well as **I.** or **E.** for the results from the measurement for the NC or the NF coating.

Parameter	Description
th.	Mean value of the single readings of the selected blocks.
s	Standard deviation. This is a measure of the deviations of the single readings of the selected blocks from their common mean value.
V	Coefficient of variation [%]. Deviation of a measurement series (block) in percent.
min	Lowest reading.
max	Highest reading.
n	Number of all single readings of the selected blocks.
** LSL	Lower specification limit setting.
** USL	Upper specification limit setting.
** n<LS	Number of block mean values (in numbers and percent) that are below the lower specification limit.
** n>US	Number of block mean values (in numbers and percent) that are above the upper specification limit.
* Confid. interval	Confidence interval. At a certain probability, the presumed "true" value of the measurement parameter lies within an interval (dual confidence interval) around the measured mean value of a measurement series.

* Values appear only on the printout; they are not shown on the display.

** Values are shown only if limit monitoring is enabled.

10.4 Sum frequency chart

The sum frequency chart (probability chart) is a graphical display format from which the outlier portion of a batch (lot, production series) can be estimated. Using the sum frequency chart, the lower violation probability and the related confidence range can be viewed for a coating thickness value and vice versa.



For a description of the statistical terms as well as the formulas used see the Glossary.

Printing measurement data, beginning on page 127.

Calling: **EVALUATE** and **E** as well as **I.** or **E.** for the results from the measurement for the NC or the NF coating.

- A minimum of 5 measurements must be available for graphical measurement data display in a sum frequency chart.
- $5 \leq n \leq 30$: The sum frequency values are plotted in reference to the single readings. The Kolmogoroff-Smirnoff Test is used to test for normal distribution of the measurements.
- $n > 30$: The sum frequency values are plotted in reference to the classes. In addition, the confidence range (error cone) is presented in the printout for a confidence level of 95 %. The Chi Squared Test is used to test for normal distribution of the measurements.
A histogram display can be opened for 30 or more measurements.
- The values appear as small black squares in the chart. The sum frequency (in %) is plotted on the ordinate (y-axis), and the electrical conductivity (in μm or mils) on the abscissa (x-axis). Display size and resolution allow only for a coarse presentation.
- If there is a normal distribution, the instrument will automatically determine a straight line. Conclusions about the deviation range can be drawn from the gradient of the line.
- If there is no normal distribution, a correction curve is plotted automatically in the chart and skewness and kurtosis are determined. This information appears only on the printout.
- The printout of the sum frequency chart offers a better resolution. Additionally, the printout shows the "u" values of the standardized normal distribution (quantile) on the right ordinate.

10.5 Histogram

A histogram clearly shows the distribution of the measurements according to classes, that is, how many measurements are within a certain coating thickness range.



For a description of the statistical terms as well as the formulas used see the Glossary.

Printing of measurement data, beginning on page 127.

Calling: **EVALUATE** , **Σ** and **HISTOGRAM** as well as **I.** or **Z.** for the results from the measurement for the NC or the NF coating.



The histogram can be called only from the sum frequency chart.

- A minimum of 30 measurements are required for the histogram display. The Chi Squared Test is used to test for normal distribution of the measurements.
- The class borders are shown on the left side and the frequency density on the right side. The display resolution and size allow only for a coarse presentation.
- If there is a normal distribution, the instrument will automatically determine a respective bell curve.
- If there is no normal distribution, skewness and kurtosis are determined. This information appears only on the printout.
- The printout of the histogram offers a better resolution. The printout also shows the frequency density in percent and in summary format.

10.6 Evaluation in the simple display and operating mode

In this special limited operating mode, the evaluation is carried out by block (block result) or across all blocks (final result).

10.6.1 Block result



Procedure and explanation as described in section "Evaluation of one block" on page 83.



Cannot be called when automatic block creation is enabled (Menu **Application/Modify Application**).

10.6.2 Final result

The evaluation performed across all blocks. When calling the Final result menu, the characteristic statistical data are displayed for all blocks.



In **applications without automatic block closure**, a block is closed automatically when the Final Result menu is called!!



The current date and time are stored whenever a block is closed (automatically or manually).



If **automatic block creation is enabled** the statistical characteristic data will be displayed as shown in the table "Final result" on page 88.



If the **automatic block creation is disabled** the statistical characteristic data will be displayed as shown in the table "Final result" on page 90. In this case, the selected (manually created) blocks will be treated as one single block for the evaluation.



Description of the softkeys beginning on page 10.
 Instrument operation beginning on page 15.
 Printer connection and settings beginning on page 127.

Procedure

Key sequence / Action	Explanation
1. FINAL RES	Calling the Final Result menu is carried out from the measurement mode.
	Navigation in the Final Result Menu:
2. 1. , 2.	Display of the results of duplex measurements for each coating: 1. : Results of the NC coating (paint) 2. : Results of the NF coating (Zn)
2. PAGE	Scrolls to the next display page to display additional results.
	and/or
PRINT	Prints the result. The printer must be connected to the instrument and must be ON.
3. RETURN	Exits the Final Result menu. Returns to the measurement mode.

11 Application (Memory for a Measurement Application)

A memory - the so-called application - must be set to make measurements. An application is defined by an application number and an application name and contains all data relevant for a measurement application as well as the measurements. An application contains data relating to the material properties and the shape of the specimen corresponding to the probe in use (normalization, corrective calibration) as well as application-specific settings that specify how the measurements are to be displayed and evaluated (e.g., large number display, specification limit monitoring, outlier monitoring, block statistics). A new measurement application is present if one of these quantities changes, and an application must be edited or a new one set up.



Various applications fitting to the probe supplied with the instrument are already set up at the factory.

11.1 Setting up an application

When setting up an application, a memory is created with specific settings (template) of the menu functions **Application/Modify Application** and **Appl. Management/Secure/Unsec. Appl.**. These pre-defined settings (templates) can be changed from the respective menu functions.



When setting up a new application, the normalization (adjustment to the coating/substrate material) and the corrective calibration (adjustment of the measuring system to the specimen) of the application that is used as a template are accepted as well.

The factory-specified default template does not contain a normalization and corrective calibration.

For measurements with Duplex probes, application memories can be set up in the so-called Duplex Mode or in the Dual Mode.

Duplex Mode

The measurement applications Lacquer/Zn/Fe (Iso/NF/Fe) and/or Lacquer/Al (Iso/NF) can be measured using this mode. The thicknesses of the individual

coatings of the duplex coating (lacquer and Zn) are displayed side by side. For the measurement application Lacquer/Al, only the lacquer coating thickness is displayed, the column for the Zn coating thickness remains empty. Also, both measurement applications can be measured in one application; the probe “recognizes” the substrate material (Fe or NF) and automatically uses the appropriate measurement method. In this case, the respective corrective calibrations must be carried out in succession for the two measurement applications (e.g., a first calibration run for Lacquer/Zn/Fe and a second calibration run for Lacquer/Al).

Dual Mode

The measurement applications Lacquer/Al (Iso/NF) and/or Zn/Fe (NF/FE) can be measured using this mode. In the measurement mode, only the coating thickness readings of one coating are displayed, either the lacquer or the Zn coating. Also, both measurement applications can be measured in one application; the probe “recognizes” the substrate material (Fe or NF) and automatically uses the appropriate measurement method. In this case, the respective corrective calibrations must be carried out in succession for the two measurement applications (Zn/Fe and Lacquer/Al).









- Define new template: beginning on page 104.
- Edit application settings: beginning on page 112.
- Secure application: beginning on page 101.
- Perform a corrective calibration: beginning on page 50.

- Descriptions of the softkeys beginning on page 10.
- Instrument operation beginning on page 15.

Procedure

Key sequence / Action	Explanation
1. MENU , 3 , 1	Press these keys in succession. Calls the menu function Appl. Management/Set up new Appl.
2. 0 ... 9	Enter a respective available number using the control panel. An available number (number without subsequent text) can be taken from the list shown on the display.

- | Key sequence / Action | Explanation |
|--|---|
| 3.  | Confirms the selected application number. Automatic change to the measurement mode of the new application. |
| 4.  | Calls the normalization function for adjusting of the measuring system to the coating and substrate material of the specimen.
 44. |
| This concludes setting up of an application. Measurements to be stored in the new application (memory) can be made immediately. A corrective calibration (adjustment of the measuring system to the specimen) is required for accurate measurements,  beginning on page 50. | |
| 5. If desired
 ,  , ... | Press these keys in succession.
Calls the desired menu function(s) for defining the desired application-specific settings.
 Description of the menu functions and parameters, beginning on page 112. |











11.2 Copying an application



All settings, normalization parameters, etc. of an application will be copied, but not the measurement data. Thus, copying refers to the application-specific settings: probe type, characteristic, normalization (adjustment to coating/substrate material), corrective calibration (adjustment of the measuring system to the specimen), measurement display mode etc.



Description of the softkeys beginning on page 10.
Instrument operation beginning on page 15.

Procedure

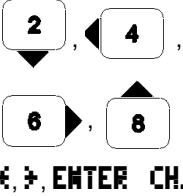
- | Key sequence/Action | Explanation |
|--|--|
| 1.  ,  ,  | Press these keys in succession.
Calls the menu function Appl. Management/Copy Application |
| 2.  ...  | Use the control panel to enter the number of the application to be copied (source).
The number can be selected from the displayed list. |
| <p> The application name, probe type, number of measurements and the used probe frequency of the listed applications can be called in succession by pressing  several times.</p> | |
| 4.  | Press this key to confirm the entry. |
| 5.  ...  | Use the control panel to enter the number for the copied application (target). An available application number (number without subsequent text) can be selected from the displayed list. |
| 6.  | Press this key to confirm the entry. |

- | Key sequence/Action | Explanation |
|--|--|
| 7.  | Enter a new name for the copy of the application.
 For entering alphanumeric characters see page 21. |
| 8.  | Press this key to accept the entries. Switch to the measurement mode of the copied application. |



The **measurement data** will not be copied!



All applications can be used as **copy source**, even secured or currently open applications. The copies can be saved **only** with an **unused application number** (memory area).



11.3 Deleting an application





Deleting the entire application, including measurement data and application-specific settings (probe type, parameters, measurement display mode, normalization (adjustment to coating/substrate material), etc.).





Description of the softkeys beginning on page 10.
Instrument operation beginning on page 15.

Procedure

- | Key sequence/Action | Explanation |
|--|---|
| 1.  ,  ,  | Press these keys in succession.
Calls the menu function Appl. Management/Delete Application |

- | Key sequence/Action | Explanation |
|---|---|
| 2.  ...  | Use the control panel to enter the number of the application to be deleted. The number can be selected from the displayed list. |
|  The application name, probe type, number of measurements and the used probe frequency of the listed applications can be called in succession by pressing  several times. | |
| 3.  | Press this key to confirm the entry. |
| 4. DELETE | Starts the delete procedure.

If additional applications are to be deleted, repeat the procedure starting at step 2. |
| 5.  | Exits the menu function. Switch to the measurement mode of the open application. |

 You cannot switch to the open measurement mode if the currently **open application** is deleted. The following message appears **APP1. not defined! Set up new APP1.<MENU 3,1> <APPL> or select existing <APPL>.**

Set up a new application,  95, or call a different application using the

 key.

 **Secured applications** cannot be deleted!

11.4 Securing/Unsecuring an application











It is not possible to use delete functions (menu functions **Appl. Management/Delete Application**, **Measurement Values/Delete Measurement**, **Measurement Values/Delete Block** and **Measurement Values/Del./Accept Block**) for secured applications. Also, a secured application cannot be edited (**Application/Modify Application**), the parameters cannot be changed. If so desired, normalization or corrective calibration (adjustment of the measuring system to the specimen) functions of a secured application can be blocked as well. All other menu functions, measurement data evaluation of the measurement data and deleting single readings with the  key are available.



- Description of the softkeys beginning on page 10.
- Instrument operation beginning on page 15.
- Unsecuring an application see page 102.

For security reasons, the menu function is password-protected by a supervisor code from unauthorized manipulations.

Procedure to secure an application

Key sequence/Action	Explanation
1.  ,  ,  	Press these keys in succession. Calls the menu function Appl. Management/Secure/Unsec. Appl.
2.  ,  ,  , 	Password-protected menu function. Press these keys in succession. Enters the supervisor code.
3.  , 	Selects the application (name) to be secured.

Key sequence/Action	Explanation
<p>4. Securing the selected application.</p> <p>1 x SECURE</p> <p>or</p> <p>2 x SECURE</p>	<p>A marker will appear to the left of an application name to indicate that the application is secured:</p> <p>"#" : Normalization and corrective calibration function still available.</p> <p>Press this key.</p> <p>"**" : Normalization and corrective calibration blocked as well.</p> <p>Press the key twice.</p> <p>If additional applications are to be secured repeat steps 3. and 4.</p>
<p>5. CONTINUE</p>	<p>Exits the menu function.</p> <p>Switch to the measurement mode of the open application.</p>









The normalization and corrective calibration (adjustment of the measuring system to the specimen) functions cannot be secured for **linked applications**.



The normalization and corrective calibration (adjustment of the measuring system to the specimen) is **unsecured automatically**, as soon as these applications are linked with other applications.

Procedure to unsecure applications

Key sequence/Action	Explanation
<p>1. MENU , 3 , 4</p>	<p>Press these keys in succession.</p> <p>Calls the menu function Appl. Management/Secure/Unsec. Appl..</p>

- | Key sequence/Action | Explanation |
|---|---|
| 2.  ,  ,  ,
 | Password-protected menu function.
Press these keys in succession.
Enters the supervisor code. |
| 3.  ,  | Selects the secured application (name) that is to be unsecured. |
| 4. Unsecuring. | |
| 1 or 2 x SECURE | Press this key.
The marker (#, *) to the left of the application disappears. |
| The selected application is unsecured.
The delete function as well as editing can again be performed for this application. If the normalization and corrective calibration functions have been secured, they will now be available again. | If additional applications are to be unsecured repeat steps 3. and 4. |
| 5. CONTINUE | Exits the menu function.
Switch to the measurement mode of the open application. |

11.5 Selecting a template for setting up new applications

Setting up of a new application is performed using a factory-default template that contains the following settings.

Default setting of the menu function **Application/Modify Application**:

Display page 1: Scientific Mode

Display page 2: i Individ. Values: 1 / Outlier Control disabled

Display page 3: Monitoring Limits disabled

Display page 4: Automatic block creation disabled

Display page 6: APPL.NO.X

Default setting of the menu function **Application/Display Format**: Medium resolution

Default setting of the menu function **Application/Display mode**: th

Default setting of the menu function **Appl. Management/Secure/Unsec. Appl.**: unsecured

These factory default settings can be replaced with a new template with your user-specific settings. One application (with or without measurements) with the desired menu functions **Application/Modify Application**, **Application/Display Format**, **Application/Display mode** and **Appl. Management/Secure/Unsec. Appl.**.

With the exception of the application name, all settings in the menu function **Application/Modify Application** of the selected application will serve as a template. If the application selected as a template is secured, the secure setting is accepted into the template as well.

Subsequent newly set up applications will automatically receive the specific settings from the template for the menu functions **Application/Modify Application**, **Application/Display Format**, **Application/Display mode** and **Appl. Management/Secure/Unsec. Appl.**.



When setting up a new application, the calibration of the application that is used as a template will be accepted automatically.



We recommend to set up a new application as a template, e.g., at position 99, with the desired settings in the menu function **Application/Modify Application, Application/Display Format, Application/Display mode** and **Appl. Management/Secure/Unsec. Appl.**, and if necessary to perform the desired corrective calibration (adjustment of the measuring system to the specimen) for this application.



Setting up an application: beginning on page 95.
 Editing an application: beginning on page 112.
 Setting the measurement resolution: page 120.
 Setting the measurement type: 121.
 Securing an application: beginning on page 101
 Performing a corrective calibration: beginning on page 50.









The factory default settings are overwritten when selecting a new template. A template cannot be deleted.



Description of the softkeys beginning on page 10.
 Instrument operation beginning on page 15.

Procedure

	Key sequence/Action	Explanation
1.	 ,  , 	Press these keys in succession. Calls the menu function Appl. Management/Appl. Template .
2.	 ... 	Use the control panel to enter the number of the application that is to serve as a template for subsequent new applications. The number can be selected from the displayed list.
3.		Press this key to confirm the entry. Exits the menu function. Switch to the measurement mode of the open application.



The application that serves as a template is marked with a black rectangle to the left of the application name in the application selection menu. Calling the application selection menu:  .

11.6 Linking of applications

It is possible to link applications via the normalization and corrective calibration. All applications that have been and are set up with the same probe (identified by the serial number) and the same probe frequency are linked to one another. All linked applications refer to **one** normalization **and** corrective calibration (adjustment of the measuring system to the specimen) that has been performed after linking.

Linking applications can be useful where similar parts are concerned that only come from different batches. In such a case, the same normalization or corrective calibration should always be referenced.

After activating the linking mode, linking will be effective only after a new normalization and corrective calibration is performed in one of the linked applications. The normalizations/corrective calibrations performed previously in these applications will be lost. All subsequent newly set up applications using this probe and probe frequency will automatically accept the existing normalization or corrective calibration and will be automatically included in the linking.





Description of the softkeys beginning on page 10.
Instrument operation beginning on page 15.

For security reasons, the menu function is password-protected by a supervisor code from unauthorized manipulations.

11.6.1 Enabling the linking mode

Procedure:

Key sequence/Action	Explanation
1. APPL , 0 ... 9 , OK	Open the application that shall be included in the linked group.
2. MENU , 3 , 6 ▶	Press these keys in succession. Calls the menu function Appl. Management/Link Applications .
3. 1 , 5 , 9 , OK	Password-protected menu function. Press these keys in succession. Enters the supervisor code.
4. ON/OFF	Enabling the linking mode. [X] Link Applications
5. OK	Confirms the setting. A message appears indicating that the locked normalization and corrective calibration function for the secured application is being unsecured.
6. OK	Exits the menu function. Switch to the measurement mode of the open application.
7. ZERO	Call the normalization function.  Procedure, see beginning on page 44.
or	
CAL	Call the corrective calibration function.  Procedure, see beginning on page 50



One normalization or corrective calibrations needs to be performed in one of the linked applications after enabling the linking to ensure that these applications use the same normalization or corrective calibration!



A block end should be performed after the corrective calibration in the linked applications.



The **locking** of the normalization and corrective calibration functions for secured applications is **automatically unlocked**, as soon as these applications are linked to other applications.

11.6.2 Disabling the linking mode

The procedure for disabling the linking mode is similar to the one described under "Enabling the linking mode". In step 4., use the softkey **ON/OFF** to disable the linking mode:

```
[ ] Link Applications .
```

12 Measurement Application Specific Settings

A separate memory area, called an application, is assigned to each measurement application. An application is defined by an application name and an application number. The correction quantity, the measurement application specific settings (e.g., specification limit monitoring, outlier monitoring, block statistics) obtained through normalization (coating/substrate material adjustment) or corrective calibration (adjustment of the measuring system to the specimen) as well as the measurements and the evaluations are stored in an application memory for each measurement application.







Setting up an application (application memory) see page 95.



















The menu functions described below apply only to active (open) applications. All of these settings are saved in the open application (memory). All other previously set up applications will not be affected by these function settings.



The function settings can be changed at any time!

The following function settings can be carried out for the active application:

Settings in the menu functions	Menu function Calling	Page
Display modes; Outlier monitoring; Generate mean display value from several single readings; Specification limit monitoring; Automatic block creation; Offset; Enter application name	Application/Modify Application  ,  , 	112
Normalization (Coating/substrate material adjustment, system adjustment)	Normalization 	44

Settings in the menu functions	Menu function Calling	Page
Corrective calibration (adjustment of the measuring system to the specimen, system adjustment)	Corrective calibration 	50
Number of displayed decimal places for the reading	Application/Display Format  ,  , 	120
Measurement display as a coating thickness value (th in μm or mils), normalized countrate (XN) or countrate (X)	Application/Display mode  ,  , 	121
Assign a new probe (different serial number) to the open application	Application/Assign New Probe  ,  , 	39
Delete all measurement data of the open application	Measurement Values/Delete Measurement  ,  , 	123
Delete measurement data of an open block	Measurement Values/Delete Block  ,  , 	124
Hide selected blocks	Measurement Values/Del./Accept Block  ,  , 	125

Settings in the menu functions	Menu function Calling	Page
Do not store readings	Measurement Values/ Store Measurements 	126

12.1 Menu function "Application/Modify Application"

Various measurement application specific settings can be specified for the open application on several display pages.

Call the menu function: **MENU**, **1**, **1**.



Description of the softkeys beginning on page 10.
Instrument operation beginning on page 15.



The menu function **Application/Modify Application** cannot be called if an **application is secured!**

12.1.1 Selecting the display modes (measurement display) menu "Application/Modify Application", display page 1

Scientific Mode

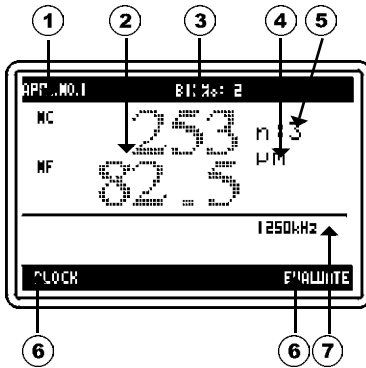

- ① Name of the current application.
- ② Reading.
NC: paint coating
NF: metal coating
- ③ Open block number.
- ④ Unit of measurement
- ⑤ Number of single readings in a block (Example for block # 2).
- ⑥ Softkeys: Calling the evaluations
 83 and 87.

⑦ Probe frequency

Statistic Mode

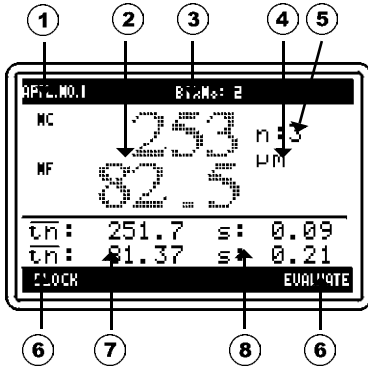

- ① Name of the current application.
- ② Reading.
NC: paint coating
NF: metal coating
- ③ Current block number.
- ④ Unit of measurement.
- ⑤ Number of single readings in a block
(Example for block # 2).
- ⑥ Softkeys: Calling the evaluations
☰ 83 and 87.

- ⑦ Mean value(s) of a block (example of block no. 2).
Upper line for NC coating (paint) and lower line for NF coating (Zn).
With applications for lacquer/Al measurements, the lower line is of no consequence.
- ⑧ Standard deviation of the mean values (example of block no. 2).
Upper line for NC coating (paint) and lower line for NF coating (Zn).
With applications for lacquer/Al measurements, the lower line is of no consequence.

- Scroll to the next display page for **additional settings**: Softkey **PAGE**.
- Accept the settings **and** exit the menu function (= switch to measurement mode): **OK**.

12.1.2 Average display value / outlier monitoring, menu "Application/Modify Application", display page 2

- Call the menu function: **MENU**, **1**, **1**.
- Scroll to the desired display page: Softkey **PAGE**.

Move the cursor to the next parameter:



i Individ. Values:

Enter the number of single readings for generating a mean value that will be displayed as the "measurement" on the display and stored in the application. For specimens made of an inhomogeneous material, it is recommended to obtain a representative mean value from several measurements and to use this value for subsequent evaluations.

Entry for "i": This value must be between 1 and 20.



This parameter is automatically disabled in continuous measurement mode.

Outlier Control

An instrument function that recognizes and marks (optically: "!", a window opens, acoustically: 2 long acoustic signals in succession) outliers.

To enable/disable outlier monitoring: Softkey **ON/OFF**.



Outlier monitoring affects only the respective block. The **block size must include at least 4 measurements!** The same applies to the entry under "i single readings" ($i \geq 4$).



Outlier monitoring is carried out after each measurement. A respective display (window) is shown at the earliest after the 4th measurement. The window disappears with the new measurement.



Measurements that have been identified as outliers do not enter the statistical evaluation. Also, these values will not be used for subsequent outlier calculations.



Because the number of available readings (n), the mean value (t_h or \bar{t}_h) and the standard deviation (s) continue to change in the course of a measurement series, a reading may be identified and displayed as an outlier even at a later point.

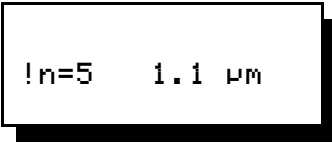

Example for the display of an outlier

Automatic

Outlier monitoring based on the Grubbs test at a statistical confidence level of $P = 90\%$.



Glossary

Input Sigma

When specifying Sigma (known deviation), the instrument checks the readings for a confidence level of $P = 99,9\%$.



Sigma (σ) must be determined by measuring representative random samples. The assumption that the deviation will not change even for subsequent measurements must be taken into account here. Under these prerequisites, specifying sigma can be used to check whether readings are compliant with regard to the representative random samples. Random sampling should include a minimum of 100 readings!

- Scroll to the next display page for **additional settings**: Softkey **PAGE**.
- Accept the settings **and** exit the menu function (= switch to measurement mode):  .

12.1.3 Specification limits monitoring, menu "Application/Modify Application", display page 3

Instrument function to monitor whether the readings are within specified limits. Upper and lower violations of the limits are signaled:

Optically	Acoustically	Meaning
▼	1 short acoustic signal	Reading has violated the lower limit.
▲	2 short acoustic signals	Reading has exceeded the upper limit.



Acoustic notification occurs only when the acoustic signal is enabled. Menu function **Output/Beep ON/OFF**: **MENU**, **4**, **1**

- Call the menu function: **MENU**, **1**, **1**.
- Scroll to the desired display page: Softkey **PAGE**.

Monitor Limits

To enable/disable specification limit monitoring: Softkey **ON/OFF**.

To move the cursor from one parameter to the next:



Lower Lim. 1

Entry box for the lower specification limit for the NC coating (paint, lacquer).

Upper Lim. 1

Entry box for the upper specification limit for the NC coating (paint, lacquer).

Lower Lim. 2

Entry box for the lower specification limit for the NF coating (Zn). Parameter

has no function with applications for lacquer/Al measurements.

UPPER Lim. 2

Entry box for the upper specification limit for the NF coating (Zn). Parameter has no function with applications for lacquer/Al measurements.

- Scroll to the next display page for **additional settings**: Softkey **PAGE**.
- Accept the settings **and** exit the menu function (= switch to measurement mode):  .

12.1.4 Automatic block creation / Offset menu "Application/Modify Application", display page 4

Automatic block creation

The readings of an application can be separated into blocks. A block consists of a certain number of readings. Blocks are always generated during a measurement run - automatically or manually. The end of a block is indicated by a key on the display.

Example: Automatic block creation is enabled and set to 5 readings per block. Measurements are made continually. After every 5 readings, the instrument will automatically generate an end of a block.

- Call the menu function: , ,  .
- Scroll to the desired display page: Softkey **PAGE**.

Fixed Block Size

To enable/disable automatic block creation: Softkey **ON/OFF** .

To move the cursor from one parameter to the next:



Meas. Per Block

Enter the number of readings to be combined in one block.

Maximum entry: 99.



If the application already contains measurements, all readings of this application will be deleted upon enabling the parameter "Fixed Block Size"!



The current date and the current time are stored together with each end of a block.



In connection with the outlier function, the block size **must be a minimum of 4 readings!**

Offset

The determined measured NC value is corrected by the defined offset value. The defined offset value will be subtracted from the measured NC value (eg. paint).

Example of an application: The coating thickness measurement on an interim coating (e.g. phosphate coating) with a known thickness that is entered as an "Offset value". Only the thickness of the top coating will be displayed.

To move the cursor from one parameter to the next:



Offset Zn/Fe:

Enter the offset value in the set unit (μm or mils). Maximum entry: 9999





Attention if the application already contains measurements! The Offset correction starts with the measurement captured after the setting. The older readings are still uncorrected. In this case no reasonable evaluation is possible. We recommend to delete all measurements from the application before setting an offset.

- Scroll to the next display page for **additional settings**: Softkey **PAGE**.
- Accept the settings **and** exit the menu function (= switch to measurement mode):  .

12.1.5 Entering the application name, menu "Application/Modify Application", display page 5

Each application is designated by a number and by an application name.

- Call the menu function:  ,  ,  .
- Scroll to the desired display page: Softkey **PAGE**.

Application Name

Enter a name with max. 16 characters.



For entering alphanumeric characters see page 21.

- To accept the settings **and** to exit the menu function (= switch to measurement mode of the open application):  .

12.2 Number of decimal places for the reading

Use this menu function to specify for the open application the number of places before and after the decimal point that are to appear for the reading/displayed value.

High Resolution

Presentation of the display value with up to 3 places after the decimal point.
0.999 / 9.99 / 99.9 / 999.9 / 9999

Medium Resolution

Presentation of the display value with up to 2 places after the decimal point.
0.99 / 9.9 / 99.9 / 999 / 9999







Low Resolution

Presentation of the display value with up to 1 place after the decimal point.
0.9 / 9.9 / 99 / 999 / 9999



Description of the softkeys beginning on page 10.
Instrument operation beginning on page 15.

Procedure

Key sequence/Action	Explanation
1.  ,  , 	Press these keys in succession. Calls the menu function Application/Display Format .
2.  , 	Select the desired resolution.
3. 	Accept the setting and exit the menu function (= switch to measurement mode of the open application).

12.3 Measurement type ("Display Mode")

Define the measurement data display mode for the open application.



Existing measurement data will be deleted when the display mode is changed!

th

Display of the coating thickness measurement in the respective unit of measurement. This quantity can be viewed directly on the display, e.g., 25 μm .



Selecting the units of measurement see page 159.

XN

Display of the normalized countrate. With the appropriate computations, the numeric value for XN will always be between 0 and 1. The normalized countrate is, therefore, ideally suited to determine if a measurement of an application is within this suitable range (0.1 to 0.95). Standards for a calibration must be within certain XN ranges. This can be checked easily by viewing the displayed XN value.

X

This is the probe signal displayed as the number of electrical impulses (real part/imaginary part). X corresponds directly to the quantity to be measured.

In general, displaying the countrate X is used to determine if there is a visible measurement signal for a particular measurement application. From the result, it can be determined if another test method might be better suited.









Description of the softkeys beginning on page 10.

Instrument operation beginning on page 15.

Further information about the countrates can be found in the Glossary.

Procedure

	Key sequence/Action	Explanation
1.	 ,  , 	Press these keys in succession. Calls the menu function Application/Display mode .
2.	 , 	Select the desired display mode.
3.		Accept the setting and exit the menu function (= switch to measurement mode of the open application).
	Delete	If measurements are already stored in the open application, they must be deleted to accept the settings.

12.4 Delete all measurement data of an open application

Only **measurement data of the open application** can be deleted. All parameter settings, the normalization (coating/substrate material adjustment) and the corrective calibration (adjustment of the measuring system to the specimen) will be retained.





Description of the softkeys beginning on page 10.
Instrument operation beginning on page 15.



This menu function cannot be executed for **secured applications!**

Procedure

	Key sequence/Action	Explanation
1.	 ,  , 	Press these keys in succession. Calls the menu function Measurement Values/Delete Measurement .
2.	DELETE	To start the deleting process. Switch to measurement mode. There are no more measurement data in the open application.

12.5 Delete all measurement data of an open block

Basically, only **open blocks** can be deleted with the menu function **Delete Block** (no key symbol is displayed). An open block is a group of measurement data where the end of the block has not yet been generated (manually or automatically, depending on the display mode, indicated by a key).

With this menu function, all measurement data back to the last closed block (key symbol) will be deleted in the open application.



The delete procedure is carried out immediately and cannot be reversed!



This menu function cannot be executed for **secured applications**.





This menu function cannot be carried out if there is no open block in the open application. In the menu list, this is indicated by an asterisk (*) to the left of the menu name:

*** Delete Block**



Description of the softkeys beginning on page 10.
Instrument operation beginning on page 15.

Procedure

	Key sequence/Action	Explanation
1.	 ,  , 	Press these keys in succession. Calls the menu function Measurement Values/Delete Block .

The delete procedure will be carried out. Return to the measurement mode of the current application.

12.6 View/Hide blocks

Hides all measurement data of one or several **closed** blocks (key symbol) in the open application. Use this menu function to hide the measurement data from the display only. They remain safe in the application memory. The measurement data of such a hidden block are in a sense locked. These measurement data do not enter the statistical evaluation.







This menu function cannot be executed for **secured applications**.



Description of the softkeys beginning on page 10.
Instrument operation beginning on page 15.

Procedure

Key sequence/Action	Explanation
1.  ,  , 	Press these keys in succession. Calls the menu function Measurement Values/Del./Accept Block .
2.  , 	Select the desired block from the list. The list shows the mean values and standard deviations for all closed blocks. Only the mean values for the NC coating (paint, lacquer) are listed.
3. ON/OFF	Show/hide a block. Hidden blocks are indicated by periods on the display. To hide additional blocks: repeat step 2. and 3.
4. CONTINUE	Exits the menu function, switches to the measurement mode of the open application.

12.7 Do not store readings

Use this menu function to specify for the open application, whether the subsequent measurement data are to be stored in the application memory or not. Not storing the measurements is indicated by a special display type in the measurement mode (see below). This display type will appear regardless of the measurement data presentation mode (scientific, statistic) selected for the application.



Description of the softkeys beginning on page 10.
Instrument operation beginning on page 15.

[X] Store Meas. Data

Menu function is enabled (default setting). The readings are stored in the memory of the open application beginning with the time when this menu function is enabled.

[] Store Meas. Data

Menu function is disabled. The readings will not be stored, beginning with the time, when this menu function is disabled. The display shown on the side will appear in the measurement mode of the open application:

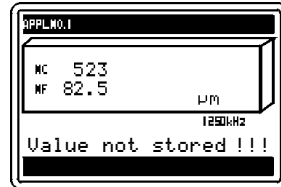

Example of the measurement mode display for the disabled menu function.

Procedure

	Key sequence/Action	Explanation
1.	, ,	Press these keys in succession. Calls the menu function Measurement Values/Store Measurements .
2.		To enable/disable the menu function.
3.		Confirm the setting and exit the menu function. Switch to the measurement mode of the current application.

13 Printing



The following printers with serial port are suitable for operation with the instrument: 9-pin printers, 24-pin printers, laser printers, Kyosha Kyoline, Seiko DPU-411 and DPU-414.

13.1 Settings for printing

Procedure

1. With the printers Kyosha Kyoline, Seiko DPU-411 and DPU-414, the following dip switch settings are required for proper data transfer (see listing). For the location of and access to the dip switches, see the respective printer manual.

Printer	DIP	1	2	3	4	5	6	7	8
Kyosha Kyoline		on	on	off	off	off	on	on	off
Seiko DPU-411	DIP01	off	off	off	on	off	off	on	on
	DIP02	on	on	off	off	off	off	-	-
Seiko DPU-414	SW-1	off	on	on	off	on	off	on	off
	SW-2	off	off	on	on	on	on	off	off
	SW-3	on	on	on	on	off	on	on	on

2. Connecting the printer: ②, Use the printer cable to connect the instrument to the printer (serial port). A special printer cable may be required depending on the printer model.
3. Select the correct printer model: in menu function **System options/Printer Selection**,  128.
4. Select the desired output mode: in menu function **Output/Output to Printer**,  129.

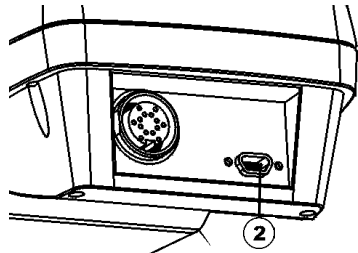

13.1.1 Selecting the connected printer model

The following printers with serial port are suitable for operation with the instrument: 9-pin printers, 24-pin printers, laser printers, Kyosha Kyoline, Seiko DPU-411 and DPU-414.

Select the connected printer model from the menu function **System options/Printer Selection**.



Printer Kyosha Kyoline, Seiko DPU-411 and DPU-414: Are the dip switch settings correct? 127.



Description of the softkeys beginning on page 10.
Instrument operation beginning on page 15.

For security reasons, this menu function is password-protected from unauthorized manipulations by a supervisor code.

Procedure

	Key sequence / Action	Explanation
1.	, ,	Press these keys in succession. Calls the menu function System options/Printer Selection .
2.	, , , 	Password-protected menu function. Enters the supervisor code.
3.	,	Select the printer.
4.		Accept the selection and exit the menu function (= switch to the measurement mode of the open application).

13.1.2 Data output mode for printing

Select, whether all measurement data and/or the block results are to be printed during or after the measurement.

Single Readings

With the printer connected, and switched ON, print the single readings directly at the moment of measurement capture. This requires a slower measurement capture rate.





Block Result

With the printer connected and switched ON, the block results with mean value, standard deviation, range, etc. of the displayed block are printed whenever the block result menu (Softkey **BLOCK**) is called and whenever a block is closed (manually or automatically).



Printing measurement data after measurement, beginning on page 130.
 Description of the softkeys beginning on page 10.
 Instrument operation beginning on page 15.

Procedure

Key sequence / Action	Explanation
1.  ,  4 , 	Press these keys in succession. Calls the menu function Output/Output to Printer .
2. ON/OFF	Enable/disable the desired output mode: <input type="checkbox"/> Parameter disabled <input checked="" type="checkbox"/> Parameter enabled
	Moves the cursors on the display.

	Key sequence / Action	Explanation
3.		Accept the selection and exit the menu function (= switch to the measurement mode of the open application).

13.2 Printing during a measurement

Procedure

1. Connect the printer and switch it ON.
2. Start the measurement.

During a measurement, either no or all single readings, and/or the block results are printed out, depending on the setting made in menu function **Output/Output to Printer**.



Setting the printing output mode, page 129.

Descriptions of the statistical characteristics can be found in the Glossary.



A printout during the measurement requires a slower measurement capture.



If a printer is connected and switched ON, the measurement data are printed automatically during **normalization** and **corrective calibration** (adjustment of the measuring system to the specimen) regardless of the setting in the menu function **Output/Output to Printer**.



The evaluation of the statistical characteristic data is carried out according to the table "Block result" on page 87.

13.3 Printing after a measurement

The measurement data and statistical evaluations can be printed after the measurement at any desired time.

13.3.1 Printing the block result after a measurement



The evaluation of the statistical characteristic data is carried out according to the table "Block result" on page 87.





Simple display and operating mode:

Softkey **ELÖCH** cannot be called when automatic block creation is enabled (menu **Application/Modify Application**).



Descriptions of the statistical characteristics can be found in the Glossary.

Procedure

Key sequence / Action	Explanation
1. ELÖCH	Calling the Block Result Menu is carried out from the measurement mode.
2.  , 	Calling the Block Result Menu is carried out from the measurement mode.
3. PRINT	Print the displayed block result. The printer must be connected to the instrument and must be ON.
4. CLOSE or CONTINUE	Exit the block result menu: Closes a open block upon exiting the menu. Exits a menu (without closing an open block).

13.3.2 Printing after a measurement according on the setting in the menu function Output/Output to Printer







Setting the printing output mode, page 129.

Descriptions of the statistical characteristics can be found in the Glossary.



The evaluation of the statistical characteristic data is carried out according to the table "Block result" on page 87.

Procedure

Key sequence / Action	Explanation
1. EVALUATE	Calling the evaluation menu is carried out from the measurement mode
2.  ... 	Enter the number of the first and the last block to be included in the evaluation.
	Moves the cursor to the next entry box.
3. PAGE	Navigation in the Evaluation Menu Scroll to the next display page for printing the data.
4. PRINT	The results will be printed corresponding to the settings in menu function Output/Output to Printer . The printer must be connected to the instrument and must be ON.
5. 	Exit the Evaluation Menu. Switches to the measurement mode of the open application.

13.3.3 Printing the final result after a measurement (the statistical characteristic data)







The evaluation of the statistical characteristic data is carried out according to the tables "Final result for an application with automatic block creation (fixed block size enabled)" on page 88 and "Final result for an application with manual block creation (automatic block creation is disabled)" on page 90.



Descriptions of the statistical characteristics can be found in the Glossary.

Printing in the simple display and operating mode, page 134.

Procedure

Key sequence / Action	Explanation
1. EVALUATE	Calling the evaluation menu is carried out from the measurement mode
2.  ... 	Enter the number of the first and the last block to be included in the evaluation.
	Moves the cursor to the next entry box.
3. STAT.	Calls the statistical characteristic data
1. , 2.	Displays the results of each coating: 1. : results from the NC coating (paint) 2. : results from the NF coating (Zn)
4. PRINT	Print the displayed result. The printer must be connected to the instrument and must be ON.
5. 	Exit the Evaluation Menu. Switches to the measurement mode of the open application.

13.3.4 Printing in the Simple Display and Operating Mode

Printing the final result, the statistical characteristic data, after a measurement



The evaluation of the statistical characteristic data is carried out according to the tables "Final result for an application with automatic block creation (fixed block size enabled)" on page 88 and "Final result for an application with manual block creation (automatic block creation is disabled)" on page 90.



Descriptions of the statistical characteristics can be found in the Glossary.

Procedure

Key sequence / Action	Explanation
1. EVALUATE	Calling the evaluation menu is carried out from the measurement mode
2. I. , Z.	Displays the results of each coating: I. : results from the NC coating (paint) Z. : results from the NF coating (Zn)
3. PRINT	Print the displayed result. The printer must be connected to the instrument and must be ON.
4. 	Exit the Evaluation Menu. Switches to the measurement mode of the open application.

13.3.5 Printing the sum frequency chart after measurement







A minimum of 5 measurements must be available for an evaluation in a sum frequency chart.



Descriptions of the statistical characteristics can be found in the Glossary.

Procedure

Key sequence / Action	Explanation
1. EVALUATE	Calling the evaluation menu is carried out from the measurement mode
2.  ... 	Enter the number of the first and the last block to be included in the evaluation.
	Moves the cursor to the next entry box.
3. Σ	Call the sum frequency chart.
I. , Z.	Displays the results of each coating: I. : results from the NC coating (paint) Z. : results from the NF coating (Zn)
4. PRINT	Print the displayed result. The printer must be connected to the instrument and must be ON.
5. 	Exit the Evaluation Menu. Switches to the measurement mode of the open application.

13.3.6 Printing the histogram after measurement







A minimum of 30 measurements are required for the evaluation in a histogram.



Descriptions of the statistical characteristics can be found in the Glossary.





Procedure

Key sequence / Action	Explanation
1. EVALUATE	Calling the evaluation menu is carried out from the measurement mode
2.  ...  	Enter the number of the first and the last block to be included in the evaluation. Moves the cursor to the next entry box.
3. Σ	Call the sum frequency chart Possible only if at least 5 measurements are available.
4. HISTOGRAM 1. , 2.	Call the histogram; possible only via the sum frequency chart Displays the results of each coating: 1. : results from the NC coating (paint) 2. : results from the NF coating (Zn)
5. PRINT	Print the displayed result. The printer must be connected to the instrument and must be ON.
6. 	Exit the Evaluation Menu. Switches to the measurement mode of the open application.

13.4 Printing the instrument settings

The set parameters in all menu functions, a list of set up applications, the memory allocation and the software version in use can be printed.

Procedure

	Key sequence / Action	Explanation
1.	 ,  ,  ,  , 	Press these keys in succession. Calls the menu function Output/Instrument Status .
2.	PRINT	Print the displayed result. The printer must be connected to the instrument and must be ON.
3.	CONTINUE	Exits the menu function (= Switch to the measurement mode of the open application)

14 Data Transfer Via RS232 Interface

A bi-directional data exchange is carried out via the RS232 interface. With a computer connected to the RS232 interface of the instrument, the following functions are available:

- Measurement data transfer from the instrument to a computer (Export).
- Remote control of the instrument by sending commands from a computer to the instrument.
- Requesting measurement data and other data (e.g., the number of the current application) by sending commands from the computer to the instrument.

Suitable commercial or self-programmed data processing software can be used to acquire and process the measurements coming from the instrument. Refer to the corresponding software manuals for information about import and processing the measurements with this software.



No data transfer via RS232 interface are possible in the **simple display and operating mode**.

14.1 Settings for the data transfer

Procedure

1. Connect the instrument and the computer using the interface cable. Use the RS232 Interface Connection Set MP.

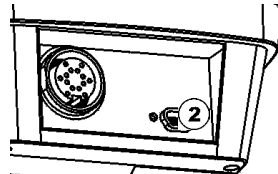

To connect the instrument to the computer, knowledge about configuration, operation and programming of the computer and of the software in use is required. If necessary, this can be obtained from the respective operator's manuals.

2. Setting the data format for the RS232 interface of the instrument: in menu function **System options/RS232 Configuration**,  140. The interface configuration of the instrument and of the connected computer must be the same.

3. Setting the data output mode for data transfer: in menu function **Output/ Output To RS232**,  142.

14.1.1 Connector pin-out

Instrument 9-pin	Signal		PC	
			9-pin	25-pin
1	not used			
2	T x D (Transmit Data)	→	3	2
3	R x D (Receive Data)	←	2	3
4	DSR (Data set Ready)	←	6	6
5	GND		5	7
6	DTR (Data Terminal Ready)	→	4	20
7	CTS (Clear To Send)	←	8	5
8	RTS (Request To Send)	→	7	4
9	connected to GND for PC connection; not used for printer connection			

For safe operation, a shielded connector cable should be used with an overall cable length according to DIN 47 100. The admissible length of this cable depends on the environmental operating conditions (guideline: 2.5 m (8 ft)).

14.1.2 Setting the data format for the RS232 interface

The interface configuration of the instrument and of the connected device (e.g. PC) must be the same. Otherwise, a proper data transfer will not be possible! The serial port configurations are set in the menu function **System options/RS232 Configuration**.

Baud rate

Data transfer rate. Since data are transferred via serial port, the transfer rate is calculated in bits per second.

Factory default setting: 9600

Parity

An error checking method, where the cross total of all bit groups transferred without error must always be an even or an odd number. Whether a parity is to be maintained or the type of parity must be defined prior to the data transfer.

Factory default setting: none

Stop bits

With serial asynchronous data transfer, the stop bit is added to the data word to be transferred. 1 or 2 bit logic Ones are used. After the stop bit, the sender remains at logic One until the start bit of the next character arrives.

Factory default setting: 1

Character length

Number of bits for presenting an ASCII character.

Factory default setting: 8

Handshake

Type of data transfer acknowledgement. One instrument sends a signal to another instrument when data are ready to be transferred.













Factory default setting: RTS/CTS



Data transfer via RS232 interface, beginning on page 144.
 Description of the softkeys beginning on page 10.
 Instrument operation beginning on page 15.
 A description of the parameters can also be found in the Glossary.

For security reasons, this menu function is password-protected from unauthorized manipulations by a supervisor code.

Procedure

Key sequence / Action	Explanation
1.  ,  ,  	Press these keys in succession. Calls the menu function System options/RS232 Configuration .
2.  ,  ,  , 	Password-protected menu function. Enter the supervisor code.
3.  ,  	Select the desired formats. Scroll to the next display page for additional settings.
4. 	Accepts the settings and exits the menu function (=switch to the measurement mode of the open application).

14.1.3 Data output to the RS232 interface

Define the output of the measurement data via the RS232-port (single readings, block result, standard deviation etc.).

Readings

At the time of the data capture, each reading is shown on the display and is simultaneously output to the RS232 interface.

Block Mean Value

If automatic block creation is enabled, the block mean value of the block shown on the display is output to the RS232 interface every time a block is closed.

Std. Dev.

If automatic block creation is enabled, the standard deviation of the block shown on the display is output to the RS232 interface every time a block is closed.

Date

If automatic block creation is enabled, the date and time of the block shown on the display is output to the RS232 interface every time a block is closed.

Separator

If automatic block creation is enabled, the set group separator is output to the RS232 interface every time a block is closed.

Selectable group separator characters: ASCII 29 | , | * | ; | \ | / | # | :











Data transfer via RS232 interface, beginning on page 144.

Description of the softkeys beginning on page 10.

Instrument operation beginning on page 15.

Procedure

Key sequence / Action	Explanation
1.  ,  ,  , 	Press these keys in succession. Calls the menu function Output/Output To RS232 .
2. ON/OFF	Enable/Disable desired output mode: [] disabled parameter [X] enabled parameter
	Moves the cursor in the display.
 ,  , 	Selects the character as group separator.
3. 	Accepts the selections and exits the menu function (= switch to the measurement mode of the open application).

14.2 Transferring data to the computer during a measurement

Procedure

1. Connect the instrument to the PC,  138. Power up both units.
2. Start the measurement.

Corresponding to the data output setting of the menu function **Output/Output To RS232**, no readings, all single readings and/or the block mean value, etc. are transferred during the measurement directly to the connected and powered up PC.



Setting the data output mode for the RS232 interface, page 142.

Enable/Disable the continuous display mode, page 80.

Enable/Disable the air value capture, page 166.

Descriptions of the statistical characteristics can be found in the Glossary.



The evaluation of the statistical characteristic data is carried out according to the table "Block result" on page 87.



Maximum measurement transfer speed: 4 measurements/second, as long as the current saving mode is set to 0 (= many, = fast).

With the maximum measurement transfer speed, it may not be possible to measure the air value, which negatively impacts the measurement accuracy.



See also Enabling/disabling the air value measurement, page 166.



The **online transfer** (transfer directly during the measurement) is possible even **with the continuous display mode enabled**.

With the continuous display mode enabled, the data is transferred directly when the probe is placed on the specimen. The parameter "Readings" must be enabled in the menu function **Output/Output To RS232**. The other parameters enabled in this menu function are not affected. To end the transfer disable the continuous display mode.

14.3 Transferring data to the computer after measurement

After the measurement, the measurement data and the statistical evaluations can be transmitted from the instrument to the PC at any desired time. The data is transmitted according to the settings in the menu function **Output/Output To RS232**.





Setting the data output mode for the RS232-port, page 142.

Descriptions of the statistical characteristics can be found in the Glossary.



The evaluation of the statistical characteristic data is carried out according to the tables "Final result for an application with automatic block creation (fixed block size enabled)" on page 88 and "Final result for an application with manual block creation (automatic block creation is disabled)" on page 90.

Procedure

Key sequence / Action	Explanation
1. EVALUATE	Calling the evaluation menu is carried out from the measurement mode.
2. 	Enter the number of the first and the last block to be included in the evaluation.
	Moves the cursor to the next entry box.
3. PAGE	Navigation in the Evaluation Menu Scroll to the next display page for transferring the data.
4. RS232	The results will be printed corresponding to the settings in menu function Output/Output To RS232 . The computer must be connected to the instrument and must be ON.

	Key sequence / Action	Explanation
5.		Exit the Evaluation Menu. Switches to the measurement mode of the open application.

14.4 Transfer from the computer to the instrument

14.4.1 Transfer formats

- All input and output data are transferred as ASCII strings followed by CRLF (Carriage Return Line Feed; CR = ASCII13, LF = ASCII10).
- Each command must end with a CR (ASCII13), LF (ASCII10) or CRLF.
- Data received by the instrument may not be longer than 20 characters.

14.4.2 Control commands

By sending the control commands from the computer to the instrument, the instrument can be remote-controlled, measurement data and other data can be requested from the instrument. The requested measurements or data will then be sent from the instrument via the RS232 interface and will be received by the computer.



Control Commands

Command to Instrument	Description
AN	Requests the maximum possible number of applications that can be set up in the instrument.

ESC = ASCII27 = ESC key of the PC keyboard / CR = ASCII13 / LF = ASCII10

Command to Instrument	Description
DAM0 ... DAM99	<p>Deletes all measurement data that is stored in the application with the given number.</p> <p>Example: The command "DAM3" will delete all measurement data of the third application.</p>
DAT0 ... DAT999	<p>Requests the date and time of the end of the block with the given number (0 ... 3999).</p> <p>Example: The command "DAT3" returns the date and time of the end of the third block of the current application.</p> <p>Example for Output: 02.07.2002 CRLF 11.09.35 CRLF</p> <p>In case of an error, the instrument transmits: "NAK".</p>
EN, ES, ESC? or G0	<p>Triggers acceptance of the measurement. The reading is stored and output from the instrument via the RS232 interface.</p> <p>In case of an error, the instrument transmits: "-99999".</p>
FD0, FD1	<p>Disables (0) or enables (1) the continuous display mode. The enabled continuous display mode is disabled automatically when the instrument is switched off.</p> <p>After the command is executed, the instrument returns "ACK" to the PC as a confirmation of the execution.</p> <p>In case of an error, the instrument transmits: "NAK".</p>
GAA	<p>Requests the number of the current application.</p>
GAN0 ... GAN99	<p>Requests the name of the application with the given number</p> <p>Example: After receiving the command "GAN3", the instrument returns the name of the third application.</p> <p>In case of an error, the instrument transmits: "NAK".</p>

ESC = ASCII27 = ESC key of the PC keyboard / CR = ASCII13 / LF = ASCII10

Command to Instrument	Description
GG	<p>Requests the block size of the open application, that is, the set number of measurements to be combined for automatic block generation.</p> <p>When automatic block generation is disabled, the number "0" will be returned.</p> <p> Enable/disable automatic block creation, page 117.</p>
GGS	<p>Requests the group separator mode.</p> <p>After receiving the command, the instrument returns:</p> <p>"0" group separator is disabled, i.e., no group separator is transmitted during the data transfer via the RS232 interface as block end identification.</p> <p>"1" group separator is enabled.</p>
GNB	<p>Requests the number of measurement blocks that are stored in the current application.</p>
IE	<p>Requests the number of single readings that are combined for a "mean measurement value" (i Individ. Values).</p> <p> Setting for i Individ. Values, page 113.</p>
IEX0 ... IEX99	<p>Checks, whether the application with the given number is set up in the instrument.</p> <p>After receiving the command, the instrument returns:</p> <p>"0" no application with this number is set up.</p> <p>"1" application with this number is set up.</p> <p>Example: After receiving the command "IEX39", the instrument returns "0", i.e., no application with the number 39 is set up.</p>
NA	<p>Requests the name of the open application (16 characters + CRLF).</p>
PE	<p>Requests the ASCII character that is used by the instrument as group separator.</p>

ESC = ASCII27 = ESC key of the PC keyboard / CR = ASCII13 / LF = ASCII10

Command to Instrument	Description
PG0	Sets the group separator in the instrument to "GS" (ASCII29).
PG1	Sets the group separator in the instrument to "," (ASCII44).
PG2	Sets the group separator in the instrument to "*" (ASCII42).
PG3	Sets the group separator in the instrument to ";" (ASCII59).
PG4	Sets the group separator in the instrument to "\" (ASCII92).
PG5	Sets the group separator in the instrument to "/" (ASCII47).
PG6	Sets the group separator in the instrument to "#" (ASCII35).
PG7	Sets the group separator in the instrument to ":" (ASCII58).
PT0	Sets the measurement output mode in the instrument to "no output".
PT1	Sets the measurement output mode in the instrument to "send single readings without group separator".
PT2	Sets the measurement output mode in the instrument to "send single readings with group separator".
PT3	Sets measurement output mode in the instrument to "send block mean values only".
PT4	Sets the measurement output mode in the instrument to "send block mean values with date".

ESC = ASCII27 = ESC key of the PC keyboard / CR = ASCII13 / LF = ASCII10

Command to Instrument	Description
RM0, RM1	<p>Enables (1) or disables (0) the remote mode. The keypad is disabled during remote mode. Display error messages and warnings do not appear. The enabled remote mode is disabled automatically when the instrument is switched off.</p> <p>After the command is executed, the instrument returns "ACK" to the PC as a confirmation of the execution.</p> <p>In case of an error, the instrument transmits: "NAK".</p>
SAM	<p>Requests all measurement data of the open application corresponding to the settings in the menu function Output/Output To RS232.</p>
SAN0 ... SAN99	<p>Overwrites the present application name for the application with the given number.</p> <p>Example: After receiving the command "SAN", the instrument returns "ACK" to the PC as confirmation of the execution. Immediately following this return message, the new name for the application # 3 must be entered (max, 16 characters). The input of the name must end with CRLF. After the name is received, the instrument again returns "ACK".</p> <p>In case of an error, the instrument answers: "NAK".</p>
SGS0, SGS1	<p>Enables (1) and disables (0) the group separator.</p> <p>After executing the command, the instrument returns "ACK" to the PC as confirmation of the execution.</p> <p>In case of an error, the instrument answers: "NAK".</p>
STATE	<p>Requests the current state of the instrument.</p> <p>After receiving the command, the instrument returns:</p> <p>"1" instrument is ready to measure</p> <p>"0" instrument is not ready to measure (no or wrong probe connected, no application is set up etc.).</p> <p>"-1" for all instrument conditions not mentioned thus far (e.g., a menu function is just being called).</p>

ESC = ASCII27 = ESC key of the PC keyboard / CR = ASCII13 / LF = ASCII10

Command to Instrument	Description
SWA0 ... SWA99	Calls the application with the given application number. Example: After transmitting the command "SWA3", the application # 3 is called in the instrument. The instrument transmits as answer "ACK". In case of an error, the instrument answers: "NAK".
VV	Requests the version name of the internal instrument software (e.g. SAA02).
XX or z	Requests the current countrate that is supplied permanently from the probe. In case of an error, the instrument answers: "NAK".
XN or y	Requests the current normalized countrate that is supplied permanently from the probe. In case of an error, the instrument answers: "NAK".

ESC = ASCII27 = ESC key of the PC keyboard / CR = ASCII13 / LF = ASCII10

Key Codes for Remote Control

Command to instrument	Description
ESC0	Operates the key 0 of the instrument control panel.
ESC1	Operates the key 1 of the instrument control panel.
ESC2	Operates the key 2 (arrow down) of the instrument control panel.
ESC3	Operates the key 3 of the instrument control panel.
ESC4	Operates the key 4 (arrow left) of the instrument control panel.
ESC5	Operates the key 5 of the instrument control panel.
ESC6	Operates the key 6 (arrow right) of the instrument control panel.
ESC7	Operates the key 7 of the instruments control panel.
ESC8	Operates the key 8 (arrow up) of the instrument control panel.
ESC9	Operates the key 9 of the instrument control panel.
ESC.	Operates the key "." of the instrument control panel.
ESC-	Operates the key "-" of the instrument control panel.
ESCM	Operates the key MEAS of the instrument control panel.
ESCN	Operates the key MENU of the instrument control panel.
ESCC	Operates the key CAL of the instrument control panel.
ESCZ	Operates the key ZERO of the instrument control panel.
ESCO	Operates the key ON/OFF of the instrument control panel.
ESCY	Operates the key OK of the instrument control panel.
ESCE	Operates the key → (TAB) of the instrument control panel.
ESCD	Operates the key DEL of the instrument control panel.

ESC = ASCII27 = ESC key of the PC keyboard / CR = ASCII13 / LF = ASCII10

Command to instrument	Description
ESCA	Operates the key APPL of the instrument control panel.
ESCR	Operates the softkey 1 (above the key OK) of the instrument control panel.
ESCS	Operates the softkey 2 (above the key →) of the instrument control panel.
ESCT	Operates softkey 3 (above the key DEL) of the instrument control panel.
ESCU	Operates softkey 4 (above the key APPL) of the instrument control panel.

ESC = ASCII27 = ESC key of the PC keyboard / CR = ASCII13 / LF = ASCII10





15 Instrument Settings







The menu functions described below are instrument settings. These settings always apply to all applications. The menu functions cover the menu names of the overview: **4 Output**, **5 Measurement Options** and **7 System options**.















The settings can be changed at any time!

The following instrument settings are possible:

Settings in the menu functions	Menu function Calling	Page
ON/OFF switch for the signal tone indicating measurement capture.	Output/Beep ON/OFF 	157
Print single reading and/or block result.	Output/Output to Printer 	129
Select the group separator and the measurement output mode for data transfer via RS232.	Output/Output To RS232 	142
Display instrument status (software version, memory allocation).	Output/Instrument Status 	158
Enable continuous display mode	Measurement Options/Free Display Mode 	80

Settings in the menu functions	Menu function Calling	Page
Select the units of measurement for the coating thickness measurement.	Measurement Options/ Select Units 	159
Set type of measurement capture.	Measurement Options/ Accept Measurement 	160
Toggle between simple and normal display and operating mode.	Measurement Options/ SIMPLE/NORMAL mode 	161
Set the battery life time and the measurement speed.	Measurement Options/ Low Power Mode 	164
Provide message when the probe requires a new air value.	Measurement Options/ Air value warning 	166
Display settings (illumination time, brightness, contrast).	System options/Adjust Brightness 	167
Set date and time.	System options/Set Date/ Time 	169

Settings in the menu functions	Menu function Calling	Page
Select the type of connected printer (pin, laser printer, etc.).	System options/Printer Selection  ,  , 	128
Set the transfer parameters for the RS232 interface (Baud rate, parity etc.).	System options/RS232 Configuration  ,  , 	140
Automatic instrument switch-off with battery operation.	System options/Autom. Switch-OFF  ,  , 	170
Select the displayed language.	System options/Language  ,  , 	27
Access to service routines for authorized personnel only.	System options/Service-Menu	

15.1 Enabling/Disabling the signal tone for the measurement capture

ON/OFF switch for the signal tone indicating measurement capture. By default, each measurement capture is indicated with a signal tone.

On

Each measurement data capture will be indicated audibly with a signal tone.







Off

The measurement capture is not signaled.



Description of the softkeys beginning on page 10.
Instrument operation beginning on page 15.

Procedure

	Key sequence / Action	Explanation
1.	 ,  4 , 	Press these keys in succession. Calls the menu function Output/Beep ON/OFF .
2.	 , 	Select the desired status (ON or OFF).
3.		Accepts the setting and quits the menu function (=switch to measurement mode of the open application).



The acoustic signals that sound after a specification limit violation, after outlier recognition or after a block end (with automatic block end enabled) cannot be disabled!!

15.2 Instrument status

Use this menu function to display the software in use and the internal memory allocation. In addition to the software version and the memory distribution, the printout also includes all instrument settings, such as brightness, contrast, illumination time, status of automatic switch-off, selected operating mode (simple/normal), delete status measurements at "FINAL RES.", selected units of measurement, selected printer, selected measurement and data output, selected group separators, type of measurement capture, status of the signal tone setting, current saving settings, type of application selected as template, status of the linking mode, set RS232 parameters as well as a list of the set-up applications.



Description of the softkeys beginning on page 10.
Instrument operation ab 15.

Procedure

	Key sequence / Action	Explanation
1.	MENU , 4 , 4	Press these keys in succession. Calls the menu function Output/Instrument Status .
2.	PRINT	Prints the instrument status.
	CONTINUE	Quits the menu function (= switch to the measurement mode of the open application).

15.3 Setting the unit of measurement

Use this menu function to specify the unit of measurement. This setting applies to all applications.

Coating Thickness







Metric SI-based units (μm , mm)

Inch Units Units used primarily in the American hemisphere (mils, inch)



Description of the softkeys beginning on page 10.
Instrument operation beginning on page 15.

Procedure

Key sequence/Action	Explanation
1.  ,  , 	Press these keys in succession. Calls the menu function Measurement Options/Select Units .
2.  , 	Select the desired unit of measurement for the coating thickness measurement .
3. 	Accepts the setting and to quits the menu function (=switch to measurement mode of the open application).

15.4 Type of measurement accept

Menu function to select the type of measurement accept.

By Probe Signal

Measurement accept (storing) after the probe is placed on the specimen.

Ext. Start

Measurement accept (storing) by sending control commands via the RS232 interface (G0, EN, ES or ESC?) to the instrument, or by pressing the key



Automatic

Automatic measurement accept. Start of the automatic measurement accept according to the above setting, either upon probe placement or by triggering an external start (sending the control command or using the  key).

Pause (sec):





Enter time after which a measurement capture is to take place. This parameter appears on the display only after the parameter "Automatic" has been enabled.

Maximum time entry: 32 Seconds.





Description of the softkeys beginning on page 10.
Instrument operation beginning on page 15.

Procedure

	Key sequence/Action	Explanation
1.	 ,  , 	Press these keys in succession. Calls the menu function Measurement Options/Accept Measurement .
2.	ON/OFF 	Enables/disables the desired measurement accept. Moves the cursor from one parameter to the next.
3.		Accepts the setting and quits the menu function (=switch to measurement mode of the open application).

15.5 Toggle between normal and simple display and operating mode

In the simple display and operating mode, only the reading, the number of measured readings per block and the set probe frequency are displayed.

In the simple display and operating mode, access to the menu functions is blocked by the supervisor code. Only those who know the code can call the menu functions. The normalization () and corrective calibration functions () (adjustment of the measuring system to the specimen) are freely accessible.



If the simple display and operating mode is enabled, all other applications will automatically appear in this mode as well.

Display presentation in simple operating mode

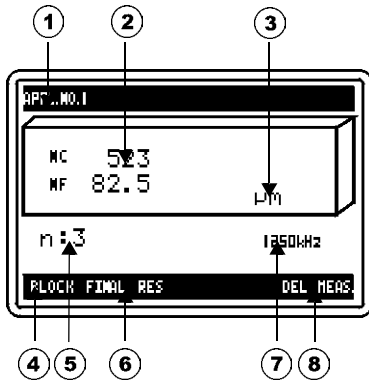

- ① Name of the current application
- ② Readings
NC: reading for paint coating
NF: reading for metal coating
- ③ Unit of measurement
- ④ Softkey: Calls the block result menu,  83.
Cannot be called when automatic block creation is enabled (Menu **Application/Modify Application**).
- ⑤ Number of single readings per block

- ⑥ Softkey: Calls the final result menu,  87.
- ⑦ Used probe frequency.
- ⑧ Deleting all measurements of the current application

Normal Meas. Modus

The display of the measurements occurs as set in the menu function **Application/Modify Application** (Scientific Mode, Statistics Mode, Spec. Limit Mode, Analog Mode). The menu function is freely accessible via the key



Simple Meas. Mode

Simple display and operating mode with the properties described above.

Delete meas. with FINAL RES













If this function is enabled, all readings of the current application will be deleted as soon as you exit the display page with the final result.



Description of the softkeys beginning on page 10.
Instrument operation beginning on page 15.

For security reasons, this menu function is password-protected from unauthorized manipulations.

Procedure

Key sequence / Action	Explanation
1.  ,  , 	Press these keys in succession. Calls the menu function Measurement Options/SIMPLE/NORMAL mode .
2.  ,  ,  , 	Password-protected menu function. Enter the supervisor code.
3.  , 	Select the desired mode.
 , 	Selected parameter "Simple Meas. Mode": Press these keys in succession, if the readings are to be deleted after viewing the final result.
4. 	Accepts the setting and quits the menu function (=switch to measurement mode of the open application).

15.6 Battery operation time and measurement speed settings

Use this menu function to set the power consumption of the instrument.

`fast <-meas.-> slow`

Setting how fast the measurement accept can take place.

Cursor display	Measurements/Second
0 (fast)	max. 4
10	≈ 3
50	≈ 1

Default setting

`0 100`

Cursor display from 0 to 100.

Factory default setting: 10

`high <-current-> low`

Set the power consumption of the instrument.

The power consumption depends (among other things) on the connected probe type and on the probe frequency used during the measurement.

	Probe frequency in kHz	Cursor display
	1250	
Batt. operation time in h	about 10 to 12 h	0 (high)
	about 18 to 20 h	100 (low)
Default setting	12 to 14 h	10



The hours of operation of the battery will be reduced significantly corresponding to the brightness setting and the illumination time when display lighting is enabled. By default the display lighting disabled.



A low current consumption necessitates a slow measurement speed, which negatively impacts the precision.



Description of the softkeys beginning on page 10.













Instrument operation beginning on page 15.

Menu function **System options/Adjust Brightness**, page 167.

Performing a corrective calibration beginning on page 50.

For security reasons, this menu function is password-protected from unauthorized manipulations.

Procedure

	Key sequence / Action	Explanation
1.	 ,  , 	Press these keys in succession. Calls the menu function Measurement Options/Low Power Mode .
2.	 ,  ,  , 	Password-protected menu function. Enter the supervisor code.
3.	 , 	Set the desired adjustments.
4.		Confirm the setting.
	 Changes in this menu function will affect the precision. Thus, a new correction calibration should be performed using the new setting (adjustment of the measuring system to the specimen).	
		Quits the menu function (=switch to measurement mode of the current application).

15.7 Enabling/Disabling the air value measurement

The instrument continuously monitors a reference value (= air value measurement). A new air value must be obtained if air values are detected that violate a factory-specified tolerance range. This prevents erroneous measurements. A corresponding display message appears if the air value violates the specified tolerance range.

The measurement can continue only after the air value has been measured (system adjustment). The operator keypad is again unlocked.

Air value monitoring can be disabled using the menu function **Measurement Options/Air value warning**. This is useful only for continues measurement capture, e.g., in a running production or for measurements in the continuous display mode if there is no need for a high measurement accuracy.









Disabling air value monitoring has a negative impact on the measurement accuracy!



Description of the softkeys beginning on page 10.
Instrument operation beginning on page 15.
Air value measurement, page 166.
Performing a normalization, beginning on page 44.

For security reasons, this menu function is password-protected from unauthorized manipulations.

Procedure

- | Key sequence / Action | Explanation |
|---|---|
| 1.  ,  ,  | Press these keys in succession.
Calls the menu function Measurement Options/Air value warning . |
| 2.  ,  ,  ,
 | Password-protected menu function.
Enter the supervisor code. |
| 3. ON/OFF | Enable/disable air value monitoring. |

Key sequence / Action	Explanation
4. 	Accepts the setting and quits the menu function (=switch to measurement mode of the open application).



To keep this measurement error as small as possible when air value monitoring is disabled, normalizations should be performed in regular intervals.

15.8 Adjust the display illumination

Use the menu function **System options/Adjust Brightness** to adjust the duration of the display illumination and the display contrast.

Illumin. Time

Time for the display illumination during battery operation. If during this time a key is pressed or a measurement made, the illumination time will be prolonged - the time restarts. This parameter is active only during battery operation.

Factory default setting: 10 s

Min. entry: 0

Max. entry: 600

Light

ON/OFF switch for the display illumination. The parameter Illumin. Time has no function when display lighting is switched off.

Contrast

Display contrast setting.

Cursor bar position fully left: minimum contrast; the dark contours fade towards a greenish color.









Cursor bar position fully right: maximum contrast; the greenish contours darken into the black color.

Default setting: Cursor bar position in the center.



Description of the softkeys beginning on page 10.
Instrument operation beginning on page 15.

Procedure

	Key sequence/Action	Explanation
1.	 ,  , 	Press these keys in succession. Calls the menu function System options/ Adjust Brightness .
2.	ON/OFF	Enables/Disables the display illumination. [] parameter disabled [X] parameter enabled
		Moves the cursor to the next parameter.
	CONTR← , CONTR→	Adjustment of the desired contrast.
		Moves the cursor to the next parameter.
	 ... 	Enter the desired illumination time.
3.		Accepts the setting and quits the menu function (=switch to measurement mode of the open application).

15.9 Setting the date and time

Use this function to set the internal system clock to the current date and time and to specify the display type for the date.

European

European date format: DD.MM.YYYY.
(D = day, M = month, Y = year)









U.S. Format

U.S. format: MM/DD/YYYY.
(D = day, M = month, Y = year)



Description of the softkeys beginning on page 10.
Instrument operation beginning on page 15.

Procedure

	Key sequence / Action	Explanation
1.	 ,  , 	Press these keys in succession. Calls the menu function System options/ Set Date/Time
2.	 ...  	Enter the current date/time. Move the cursor to in the display.
3.	 , 	Select the desired display type for the date display.
4.		Accepts the setting and quits the menu function (=switch to measurement mode of the open application).

15.10 Setting automatic switch-off for battery operation

Use this menu function to set a time period after which the instrument will switch OFF automatically if no key of the control panel is pressed, no measurement is carried out, or no data are transferred to the printer or via the RS232 port during this time. After the instrument has switched off automatically, it must be switched on again using the key  to make measurements.











This menu function is not carried out if the instrument is connected directly to line voltage (green LED lights).



Description of the softkeys beginning on page 10.
Instrument operation beginning on page 15.

For security reasons, this menu function is password-protected from unauthorized manipulations by a supervisor code.

Procedure

	Key sequence / Action	Explanation
1.	 ,  , 	Press these keys in succession. Calls the menu function System options/ Autom. Switch-OFF .
2.	 ,  ,  , 	Password-protected menu function. Enter the supervisor code.
3.	 ... 	Enter the desired time period. Entry 0: automatic switch-OFF is disabled Max. Entry: 99
4.		Accepts the setting and quits the menu function (=switch to measurement mode of the open application).

16 Technical Data

Power supply:

A/C power supply: 100 ... 240 Vac, 47 ... 63 Hz
 (length of cord approx. 2 m (6.6 ft))
 Power consumption: max. 4.5 W
 with exchangeable plug adapters (Euro-Standard, US-Standard, UK-Standard)

Battery:

NiCd, 4.8 V= /1000 mAh
 Battery operating times:

	Probe frequency in kHz
	1250
min. h	10 to 12
max. h	18 to 20
Default setting, h	12 to 14



The battery operating time will be reduced significantly corresponding to the illumination time when the display lighting is enabled. By default, display lighting is disabled.

Weight:

600 g (1.3 lbs) (instrument with battery)

Dimensions:

Instrument (L x W x D): 230 x 95 x 52 mm
 (9 x 3.7 x 2 ")
 backlit LCD graphics display: 62 x 43 mm (W x H)
 2.4 x 7.7 " (W x H)

Admissible ambient temperature range during operation:

+5 ... +50 °C (+41 ... +122 °F)

Admissible storage conditions:

Storage temperature: +5 ... +60 °C (+41 ... +140 °F)
 relative humidity: 30 ... 90 %, non-condensing

Test method:

Phase-sensitive eddy-current test method according to ISO 21968 and magnetic induction test meth-

od

Applications: up to 100

Storage capacity: up to 20,000 measurements, which may be combined into up to 4,000 blocks

Measurement accept: max. 4 readings per second, if "0" (= fast, = high) is set in the menu function **Measurement Options/ Low Power Mode**,  164.

Measurement presentation:
scientific mode, statistics mode

Display and operating modes: normal or simple,  161.

Evaluation: mean value, standard deviation, range, minimum value, maximum value, number of measurements, number of blocks, Cp, Cpk, specification limit violations
sum frequency chart, histogram

Connectors:

14-pin round plug: Probe

9-pin micro-D-plug: RS232 interface
bidirectional (data transfer to an external computer and remote control of the instrument by sending commands from an external computer)
 Connector pin-out see page 139.

Calibration standards: $0.02 \leq X_{NStandard} \leq 0.95$.
The standard values should be evenly distributed within the interesting measurement range.



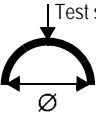
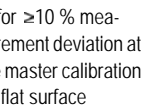
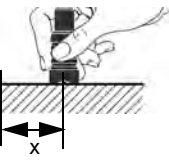

Probe ESG20

Probe type	ESG20		
	Paint/Zn/Fe (Iso/NF/Fe)	Paint/Al (Iso/NF)	NF/Fe (z.B. Zn/Fe)
Measurement range	<p>Paint:</p> <p>0 ... 550 μm <i>0 ... 22 mils</i></p> <p>electroplated Zn coat.:</p> <p>0 ... 150 μm <i>0 ... 6 mils</i></p>	<p>0 ... 2000 μm <i>0 ... 80 mils</i></p>	<p>0 ... 700 μm <i>0 ... 28 mils</i></p>
Repeatability precision referenced to Fischer Standards	<p>Paint</p> <p>2 ... 100 μm: 0.5 μm 100 ... 500 μm: 0.5 % of reading</p> <p><i>mils: 0.08 ... 4: 0.02</i> <i>mils: 4 ... 20: 0.5 % of r.</i></p> <p>electropl. Zn coating</p> <p>2 ... 30 μm: 0.1 μm 30 ... 100 μm: 0.3 % of reading</p> <p><i>mils: 0.08 ... 1.2: 0.004</i> <i>mils: 1.2 ... 4: 0.3 % of r.</i></p>	<p>5 ... 100 μm: 0.5 μm 100 ... 2000 μm: 0.5 % of reading</p> <p><i>mils: 0.2 ... 4: 0.02</i> <i>mils 4 ... 80: 0.5 % of r.</i></p>	<p>2 ... 100 μm: 0.5 μm 100 ... 600 μm: 0.5 % of reading</p> <p><i>mils: 0.08 ... 4: 0.02</i> <i>mils: 4 ... 24: 0.5 % of r.</i></p>
Trueness referenced to Fischer Standards	<p>Paint for Zn coating thicknesses $\leq 30 \mu\text{m}$ (<i>1.2 mils</i>):</p> <p>2 ... 100 μm: $\pm 1 \mu\text{m}$ 100 ... 500 μm: $\pm 1 \%$ of reading</p> <p>mils: 0.08 ... 4: ± 0.04 mils: 4 ... 20: $\pm 1 \%$ of r.</p> <p>Paint for Zn coating thickness 30 ... 100 μm (<i>1.2 ... 4 mils</i>)</p> <p>2 ... 100 μm: $\pm 2 \mu\text{m}$ 100 ... 500 μm: $\pm 2 \%$ of reading</p> <p><i>mils: 0.08 ... 4: ± 0.08</i> <i>mils: 4 ... 20: $\pm 2 \%$ of r.</i></p>	<p>5 ... 100 μm: $\pm 2 \mu\text{m}$ 100 ... 2000 μm: $\pm 2 \%$ of reading</p> <p><i>mils: 0.2 ... 4: ± 0.08</i> <i>mils: 4 ... 80: $\pm 2 \%$ of r.</i></p>	<p>2 ... 100 μm: $\pm 1 \mu\text{m}$ 100 ... 400 μm: $\pm 1 \%$ of reading 400 ... 600 μm: $\leq 2 \%$ of reading</p> <p><i>mils: 0.08 ... 4: ± 0.04</i> <i>mils: 4 ... 16: $\pm 1 \%$ of r.</i> <i>mils: 16 ... 24: $\pm 2 \%$ of r.</i></p>

Probe type	ESG20		
Coating/substrate material	Paint/Zn/Fe (Iso/NF/Fe)	Paint/Al (Iso/NF)	NF/Fe (z.B. Zn/Fe)
Trueness referenced to Fischer Standards	electropl. Zn coating: 2 ... 30 μm : $\pm 0.5 \mu\text{m}$ 30 ... 100 μm : $\pm 1 \mu\text{m}$ <i>mils: 0.08 ... 1.2: ± 0.02</i> <i>mils: 1.2 ... 4: ± 0.04</i>		
Probe tip diameter	\varnothing 1.5 mm (60 mils)		
Min. radius on the test area	R = 4 mm (0.16") for convex curvature		
 Test spot  Ø for ≥ 10 % measurement deviation at the master calibration on flat surface	$\varnothing \leq 22$ mm (0.87") Measurement deviation for 75 μm (3 mils) paint thickness: +10 % for 21 μm (0.84 mils) Zn thickness: -4.5 % $\varnothing \leq 10$ mm (0.39") Measurement deviation for 75 μm (3 mils) paint thickness: +22 % for 21 μm (0.84 mils) Zn thickness: -10 %	$\varnothing \leq 385$ mm (15.16") (for 100 μm (4 mils) paint thickness)	$\varnothing \leq 16$ mm (0.63") (for 100 μm (4 mils) paint thickness)
 Measurement deviation for edge distance x	$X = 1$ mm (3.9") Measurement deviation for 75 μm (3 mils) paint thickness: +21 % for 21 μm (0.84 mils) Zn thickness: -9 % $X = 2$ mm (6.8") Measurement deviation for 75 μm (3 mils) paint thickness: +10 % for 21 μm (0.84 mils) Zn thickness: -4 %	$X \leq 5$ mm (0.2") Measurement deviation for 100 μm paint thickness: +10 %	$X = 1$ mm (3.9") Measurement deviation for 100 μm (4 mils) NF thickness: ≤ 5 %

Probe type	ESG20		
Coating/substrate material	Paint/Zn/Fe (Iso/NF/Fe)	Paint/Al (Iso/NF)	NF/Fe (z.B. Zn/Fe)
Substrate material thickness for error $\geq 10\%$	≤ 0.3 mm (<i>12 mils</i>) (for $75\ \mu\text{m}$ (<i>3 mils</i>) paint thickness and $21\ \mu\text{m}$ (<i>0.84 mils</i>) Zn thickness)	≤ 0.2 mm (<i>8 mils</i>) (for $100\ \mu\text{m}$ paint thickness)	≤ 0.33 mm (<i>13 mils</i>) (for $100\ \mu\text{m}$ NF thickness)
Min. test area diameter	$\varnothing 10$ mm (<i>0.39"</i>)		
Probe length	120 mm (<i>4.72"</i>)		
Probe diameter	19 mm (<i>0.75"</i>)		
Probe/Measurement frequency	1250 kHz		
Test method	Phase sensitive eddy current test method according to ISO 21968	Magnetic induction test method according to ISO 2178	
Measurement application Master Calibration	Specimen with a flat, smooth surface		

18 Malfunction? What To Do

Trouble/Message	Cause/Trouble Shooting
<i>Nothing on the display</i>	<ul style="list-style-type: none"> ● Instrument is not switched ON. <i>Switch the instrument ON.</i> ● Instrument has switched OFF automatically (automatic switch-off with battery operation). <i>Switch the instrument ON.</i> ● Instrument battery is discharged and the instrument is not connected to line power. <i>Connect the instrument to line power,  14 and 28.</i>
<i>Probe does not make measurements</i>	<ul style="list-style-type: none"> ● Probe placed on the specimen incorrectly. <i>Place the probe correctly on the specimen,  beginning on 37.</i> ● Wrong probe connected to the instrument. Probe flashes in the upper right display corner. <i>Connect the probe that has been used to set up the current application.</i> ● No measurement spot because, for example, the coating thickness is too small. <i>Try a different spot; the probe may not be suitable for the coating thickness measurement at the respective specimen. Observe the measurement range of the probe,  171 and beginning on 43.</i> ● Probe requires new air value (reference value). <i>Follow the display prompts,  26.</i>

Trouble/Message

Cause/Trouble Shooting

- Automatic measurement accept is disabled.
Measurement accept must be triggered using "External Start": Key → or G0.
- Wrong specimen (wrong coating/substrate material combination).
Use a specimen with a coating/substrate material combination for which the current application has been set up. Or set up a new application for the respective specimen,
☰ 95.
- Wrong application selected.
*Select an application that corresponds to the respective specimen: Key **APPL**.*
- Erroneous normalization/corrective calibration.
Carefully perform a new calibration, ☰ 50.
- Probe is defective.
Replace probe, ☰ 39.



Wrong readings

- Wrong application selected.
*Select an application that corresponds to the respective specimen: Key **APPL**.*
- Normalization/corrective calibration not suitable for the respective measurement application.
Delete the normalization/corrective calibration and perform it again using suitable standards, ☰ 44.
- Probe incorrectly placed on specimen.
Place probe correctly on specimen,
☰ *beginning on 37.*

Trouble/Message

Cause/Trouble Shooting

- Operation of instrument close to strong magnetic fields.
Look for a different measurement location or remove the magnetic field source.

- Measurement on substrate material from various batches causes in wrong readings if the physical properties (permeability or electrical conductivity) of the materials from the various batches are different.
Adjust probe and instrument to the corresponding material properties of each batch.
Perform a normalization  44, or a corrective calibration, .

- The temperature of the specimen during measurement differs to the temperature of the standards during the normalization/corrective calibration.
Perform a new normalization/corrective calibration. Take into account, that the temperature of the standards during normalization/corrective calibration must be the same as the temperature of the specimen during the measurement.  /50.





Printer does not print

- Printer is not switched ON.
Switch the printer ON.
- Printer battery discharged and printer not connected to AC power line.
Connect the printer to AC power.
- Printer not connected to the instrument.
Connect the printer to the RS232-port of the instrument.



Trouble/Message

Cause/Trouble Shooting

No data transfer to the computer

- Connection cable between the instrument and the printer is defective.
Replace the connection cable.
- Wrong printer type selected in the instrument.
Select the printer type in the instrument that fits the connected printer,  128.
- Data output disabled.
Enable data output,  129.
- Interface configurations of instrument and computer are not the same.
At the instrument, set the same interface configuration that is set at the computer,  140.
- Data output disabled.
Enable data output,  142.
- Incorrect connection between computer and instrument.
Check connections/connectors
- Connection cable between computer and instrument defective.
Replace connection cable.

Probe flashes

- Wrong probe connected to the instrument.
Probe flashes in the upper right display corner.
Connect the probe that has been used to set up the current application,  95.
Assign new probe to the current application,  39.

Trouble/Message

 flashes

FULL flashes

Missing Probe!



Normalization

With Probe in air
press GET Xs.

Measurement data
out of measuring
range!

Measured air value
for this Probe may
no longer be
valid. Hold probe
in air and push
'GET Xs'.

Cause/Trouble Shooting

- Low battery voltage.
Recharge battery,  28 and 33.
- The measurement memory is full. No additional readings can be stored.
Delete measurements or applications,  123 or 99. For data storage transfer measurements to a PC,  138.
- No probe connected to the instrument.
Connect the probe, then press the softkey
CONTINUE.

- The measuring system requires a reference value (air value).

Follow the instructions,  26.

- Wrong specimen (wrong coating/substrate material combination).
Use a specimen with a coating/substrate material combination for which the current application has been set up. Or set up a new application for the respective specimen

 95.

Close the message window using the OK button of the control panel.

- The measuring system requires a reference value (air value).

Follow the instructions,  26.

Trouble/Message

Cause/Trouble Shooting

Standard sequence
invalid!
Corrective
calibration
not possible.

Attention:
Difference between
XN values less
than 0.1! One
point Calibration
will be performed.



- Missing normalization.
Normalization for NC/NF/Fe or lacquer/Al is missing!

Perform the missing normalization,  44.

For applications where only lacquer/Al is to be measured, a normalization for paint/Zn/Fe must be performed as well! If an Fe substrate material and a Zn saturation are not available, use the standards (NF/FE, ISO/NF boards) that were shipped with the probe.

Close the message window using the OK button of the control panel.

- The standard value entered does not agree with the measured one.
Perform the corrective calibration (adjustment of the measuring system to the specimen) again and check the standard entry and values,  beginning on 50.

- Corrective calibration has been performed with an unfit 2nd coated calibration standard (calibration foil).
Delete the corrective calibration (adjustment of the measuring system to the specimen),  61, and perform a new one with a suitable 2nd standard,  52 and 58.

Trouble/Message



Measurement is outside of proper range! Corrective calibration not possible.

Cause/Trouble Shooting

- Unsuitable standards (e.g., wrong coating material) used for the corrective calibration (adjustment of the measuring system to the specimen).
 Example: Corrective calibration with ESD20 Zn probe, open application for Cu/Fe, however, corrective calibration carried out with Zn/Fe standards.
Perform the corrective calibration again, but with the correct standards,  beginning on 50.

19 Glossary (Terms and Formulas)

Accuracy

Qualitative designation for the approximation of the measurement result to the true value. Usually, accuracy is divided into  *Trueness* and  *Precision*.

Adjustment  *Calibration*

Application

Measurement task of the user.

The memory, where the coefficients from the corrective calibration/normalization (adjustment of the measuring system to the specimen/coating/substrate material adjustment; system adjustment), the parameter settings and the measurement data for a certain measurement application of the user are stored is called an application.

Application Memory

Instrument memory, contains all data and the measurements for a measurement application.

Application Selection

Menu page(s), where all previously defined applications are listed. Use the key APPL to call the list of application.

Automatic Block Creation

A block is closed automatically each time a specified number of measurements (readings) is reached. In statistical evaluations, block mean values are used instead of single readings.

Baud Rate

Data transfer rate. Used mainly in connection with terminal programs for data transfer. Since data are transferred via a serial port, the transfer rate is calculated in bits per second.

Baud

Unit of the speed for transferring information (data) via a serial port. 1 baud corresponds to a transfer rate of one bit per second.

Bell Curve  *Normal Distribution*

Bidirectional Data Exchange

Data can be transmitted and received by both participants (for example, from the instrument to the PC and from the PC to the instrument).

Bit

(Binary Digit), binary number. 1 bit is the smallest unit in the binary number system. The value of a bit is either 0 or 1. Being the smallest unit of information in a computer, a bit forms the basis of every computer system. 8 bits are combined to a byte, or several bytes to a word.

Block end

Identification after n measurements. A block end can be carried out automatically or manually using a softkey. The block end is usually indicated by a key symbol on the display.

Block

Group of n single readings. Several measurements are combined to a block. A key symbol in the display indicates the end of each block.

Block Mean Value  $th.$, \bar{th} **Block Result**

Statistical evaluation of the measurements of a block: mean value, standard deviation, coefficient of variation, range, minimum value, maximum value, number of single readings per block.

Block Size

Number of single readings combined to form one block.

Block, open

Group of single readings, where the block has not yet been closed.

Calibration Curve

(Characteristic, master characteristic) Quantitative relationship between the probe signal and a function of the electrical conductivity as defined by calibration standards.

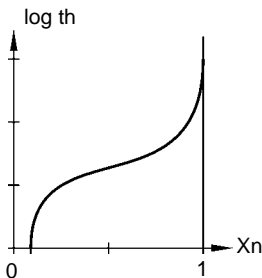

The coating thickness th is displayed in relation to the normalized count rate X_n as a calibration curve. The mid portion of the calibration curve approaches a straight line. This is the range with the smallest relative measurement error.

As long as no normalization (coating/substrate material adjustment) or

corrective calibration (adjustment of the measuring system to the specimen) has been performed, the calibration curve is identical with the master calibration curve. During a normalization or corrective calibration the calibration curve is adjusted to the individual measurement application and the coefficients of the normalization or corrective calibration are stored in the current application.

Calibration Standard

Object with the same attributes (or as close as possible) as the specimen that differs only in the coating thickness; its coating thickness has been measured with an extremely accurate test method.

Calibration

In this manual, the term calibration is used as a comprehensive term for the adjustment and the calibration: Adjustment of the instrument to adapt the measuring system (instrument and probe) using calibration standards.

Capability Factors

The process capability is evaluated with the factors C_p and C_{pk} . For detailed information see, for example, Ford Guideline Q101.

The capability factor C_p is a measure for the deviation of a process and its ability to continuously produce parts according to specifications.

The capability factor C_{pk} takes into account the position of the mean value in relation to set limits.

$$C_p = \frac{USL - LSL}{6 \cdot \hat{\sigma}} \quad \text{and} \quad C_{pk} = \left\{ \frac{USL - th..}{3 \cdot \hat{\sigma}} \quad ; \quad \frac{th.. - LSL}{3 \cdot \hat{\sigma}} \right\}$$

th..: Average of all subgroup mean values

$\hat{\sigma}$: Estimate value for the theoretical standard deviation $\hat{\sigma} = \sqrt{\frac{1}{n_{B1}} \cdot \sum_{i=1}^{n_{B1}} s_i^2}$

n_{B1} : Number of blocks

s_i : Standard deviation of the blocks

USL: Upper specification limit

LSL: Lower specification limit

Carriage Return (CR)

CR is a character of the ASCII character set (ASCII13) and has the following function: when data or commands are entered, the line that the user is currently working on will be closed by pressing the CR key (Enter or Return key on the PC keyboard); the information entered will be processed accordingly. The cursor is again placed at the beginning of the line. CR is usually used together with the LF (Line Feed) character to start the next line at the beginning of the line.

Characteristic Calibration Curve

Chi-Squared Test

Statistical mathematical test method to determine the normal distribution of the measurements (for more than 30 measurements only).

Class

Range between a lower and an upper class boundary (limit values). The measurement data of a measurement series can be sorted according to classes of equal width which cover the entire range of the measurement series. The class contents (frequency or number of measurements per class) plotted for each class is called a histogram.

Coefficient of Variation V

Confidence Borders

An area of the sum probability chart where the sum curve can be found. With a 95% confidence (confidence level), the true lower portion of the respective parameter value (e.g. electrical conductivity) can be found within these borders. For normal distribution, the confidence borders p_{top} and p_{bottom} are calculated as follow:

$$p_{bottom} = \frac{th - th.}{\hat{\sigma}} - \left(1.96 \cdot \sqrt{\frac{1}{n} + \frac{\left(\frac{th - th.}{\hat{\sigma}}\right)^2}{2n - 2}} \right)$$

p_{bottom} : Lower confidence border
 p_{top} : Upper confidence border
 th : Measurement
 $th.$: Mean value
 n : Number of single readings

$$p_{top} = \frac{th - th.}{\hat{\sigma}} + \left(1.96 \cdot \sqrt{\frac{1}{n} + \frac{\left(\frac{th - th.}{\hat{\sigma}}\right)^2}{2n - 2}} \right)$$

$\hat{\sigma}$: Estimated value for the standard deviation σ of the population

And for measurements that do not have normal distribution, the confidence borders are entered into the probability chart as a polygon and are calculated as follows:

$$p_{bottom}(i) = y_p(i) - \left(1.96 \cdot \sqrt{\frac{1}{n} + \frac{(y_p(i))^2}{2n - 2}} \right)$$

$y_p(i)$: y-values of the polygon (sum curve when the measurements do not have normal distribution) with $i = 1$ to $n - 1$.

$$p_{top}(i) = y_p(i) + \left(1.96 \cdot \sqrt{\frac{1}{n} + \frac{(y_p(i))^2}{2n - 2}} \right)$$

Confidence Interval  *u*

Confidence Level  *u*

Continuous Display Mode

With the probe placed on the measuring object, measurements will be displayed continuously. Use the key \rightarrow for measurement accept. Call menu function **Messoptionen/Freilauf ein** to enable the continuous display mode.

Corrective Calibration

One-point or two-point calibration. Adjustment of the instrument using one or two calibration standards. The corrective calibration includes calibration and adjustment.

During corrective calibration, the master characteristic (calibration curve) is adjusted to the individual measurement application. The coefficients of the adjusted calibration curve are stored in the open application. The master characteristic itself remains unchanged.

Countrate

X (Phi). This is the probe signal displayed as the number of electrical impulses. Phi corresponds directly to the measured quantity. The Phi value will range between the two extremes X_{\min} and X_{\max} .

In general, displaying the countrate X is used to determine if there is a viable measurement signal for a particular measurement application.

The numeric values of the normalized countrate XN are between 0 and 1 and are computed according to the following equation:

$$XN = \frac{X - X0}{XS - X0}$$

XN: Normalized countrate
 X: Countrate of the measurement
 X0: Countrate at base material, specimen without coating
 XS: Countrate in air or at coating material (saturation)

Cp:  *Capability Factors*

Cpk:  *Capability Factors*

CR:  *Carriage Return (CR)*

Cu

Abbreviation for Copper

Curvature

Excess and Kurtosis are measures for the curvature (e.g. how pointed or how wide) of a distribution compared to a normal distribution. A positive Kurtosis indicates a relatively narrow, pointed distribution; a negative Kurtosis indicates a relatively flat distribution. The Kurtosis of a normal distribution is Zero.

Data Transfer Rate  *Baud Rate*

Deviation of the Block Mean Values  *sa*

DIP Switch

DIP = Dual Inline Package = electronic component ready to be installed. In this case, a series of little switches. They are often used in peripheral devices, e.g., in printers, to change the basic settings of the device.

Eddy Current Method, amplitude sensitive (ISO 2360)

The excitation current generates a high-frequency magnetic field that induces eddy currents in the material. The development of these eddy currents depends on the distance (coating thickness) between the probe and the substrate material. The measurement signal, which captures the reaction of the magnetic field of the eddy currents to the original magnetic field, is converted into a reading that is proportional to the coating thickness.

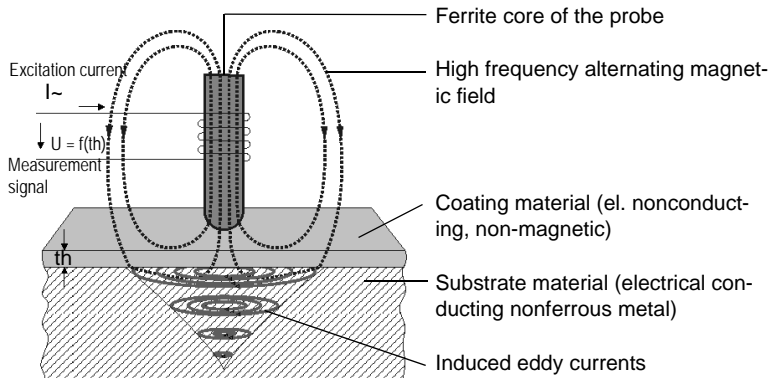

Principle of the amplitude sensitive eddy current method

Eddy Current Method, phase sensitive (ISO 21968)

The excitation current generates a high-frequency magnetic field that induces eddy currents in the material (coating or substrate material). The

different formation of the eddy currents in the coating material and the substrate material is used for the coating thickness measurement. The phase shift φ between the excitation current and the measurement signal is converted to a coating thickness value.

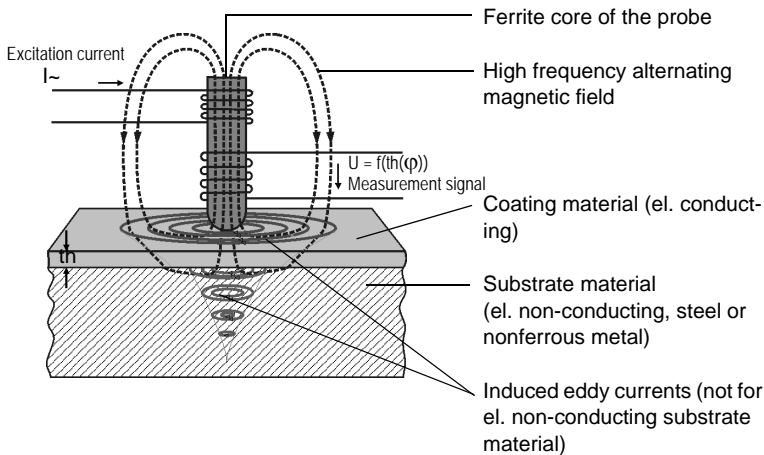

Principle of the phase sensitive eddy current method

This measuring method has significant advantages for the thickness measurement of metallic surface coatings. By using the phase position of the probe signal instead of the amplitude for the coating thickness computation, the interfering influences of the specimen shape and of the probe lift-off are significantly reduced.

Error Cone  *Confidence Borders*

Estimated Value for the Coefficient of Variation  \hat{v}

Estimated Value for the Standard Deviation  $\hat{\sigma}$

Evaluation

Calculation of statistical parameters, such as mean value, standard deviation, etc., as well as the graphical display of measurements, e.g., in a sum frequency chart.

Evaluation Menu

Selection menu for the evaluation and display of the measurement data, and data (measurement, evaluation) output via RS232 interface or to printer. Use the softkey EVALUATE to call the menu.

Excess  *Curvature*

External Start

Setting in the menu function **Messoptionen/Messwertübernahme**. Triggers measurement accept by pressing the key \rightarrow , by sending the command G0 from the connected computer or by using a connected pedal switch.

Fe

Abbreviation for magnetizable material of steel or iron.

Final Result

Evaluation of all measurements or of selected blocks stored in the current application.

Frequency Distribution  *Histogram*

Gaussian Distribution  *Normal Distribution*

Gaussian Normal Distribution  *Normal Distribution*

Gaussian Probability Paper  *Sum Frequency Chart*

Group Separator

The end of a block can be marked with a group separator. The group separator can be transferred with the measurement data to the computer. Default setting ASCII character 29.

Grubbs Test

Test method for outlier rejection. A method by Grubbs, used to test whether the highest or the lowest single reading should be considered an outlier.

Histogram

Graphical display of all single readings of an application according to classes (e.g., coating thickness ranges), where the class frequency is illustrated by the contents of rectangles. The class widths should be equal. Among other criteria, the meaningfulness of statistical results depends on the shape of this distribution curve.

Instrument Memory  *Application*

Interface

Transfer and connecting points between components, circuits and programs. Interfaces are used for data exchange.

With serial interfaces, the data are transferred in individual bits (i.e., one

bit after another), with parallel interfaces, several bits are transferred simultaneously.

Kolmogorow-Smirnow Test

Statistical mathematical test method to determine the normal distribution of the measurements (for 5 to 30 measurements).

Kurtosis  *Curvature*

LF  *Line Feed*

Line Feed

Advances the printer paper by one line. It is usually used together with the CR (carriage return) character to start the next line at the beginning.

LSL

Lower specification limit, is the minimum reading that is permitted at the measurement spot.

Magnetic Induction Method

Contact test method. A low frequency AC excitation current generates a low frequency magnetic field. The magnetic flux density depends on the distance between the measurement probe and the ferromagnetic substrate. A probe output signal is generated by means of a pick-up coil. The instrument translates the measurement signal to coating thickness based on the probe characteristic and a suitable mathematical conversion model.

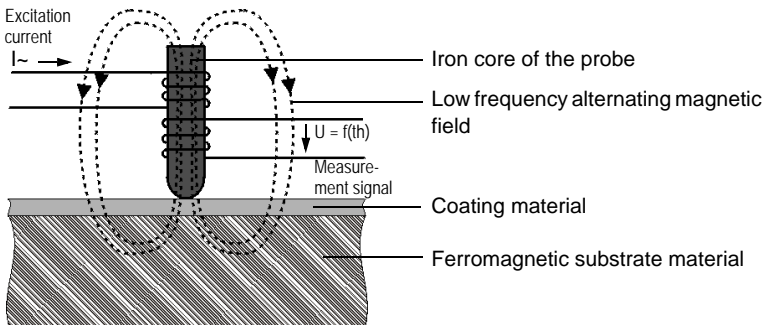

Principle of the eddy current method

Master Characteristic (Master Calibration Curve)

(Probe characteristic) Original characteristic of the measuring system. It is the basis for determining the measurement values, since it represents the relationship between the probe signal and the coating thickness. The coefficients of the master calibration curve are stored in the probe connector.

Max

Highest measured value of a test series.

Maximum  *Max*

Maximum Value

Highest measured value of a test series (block).

Mean Range  *R*.

Mean Value  *th*.

Mean Value of the Block Mean Values  *th..*

Measurement Accuracy  *Accuracy*

Measurement Application

Properties of the test specimen with regard to measurement quantity, material, geometric dimensions, permeability, etc. The test method, the measurement display mode, the probe and the type of instrument are all determined by the measurement application.

Measurement Data Presentation

Refers to the type of display presentation of measurement data. 2 types of presentations are available in the PMP10 DUPLEX: scientific mode and statistics mode.

Measurement Error

The difference between the actual and measured value of a measured quantity. For measuring instruments, there is a distinction between random (unpredictable) and systematic (correctable) errors. Random errors determine the repeatability precision. Systematic errors affect the trueness and the reproducibility.

Systematic errors are far more prevalent in practical measurement applications. Systematic errors can be traced back to: 1. faulty calibration, 2. operator related errors, or 3. changes in test conditions (inhomogeneities, instabilities, aging of the material, etc.). Systematic errors tend to lean in one direction. With appropriate care, causes 1. and 2. can usually be avoided or corrected or taken into account in the measurement result.

Measurement Test Series

A series of single readings between two block or final results.

Measurement Uncertainty  *u*

Measurement

Numeric reading of an instrument, expressed in the unit of measurement. The measurement can be obtained as the result of a single reading or as arithmetic mean of several single readings (parameter "i Individual Values = single readings").

Measuring Mode

The condition in which the instrument can capture and display measurement data. The display mode is determined by the measurement type setting of the instrument.

Measuring Position

A limited and clearly defined point within the reference surface of the specimen, where the coating thickness is to be determined.

Measuring Probe  *Probe***Measuring Range**

The range between the two limits within which a measurement is possible at a specified trueness and precision. In a narrower sense, it refers to the range of the scale of an analog instrument. The measuring range depends on the measurement method, the design of the probe and the measurement application.

Measuring System Check

A significant part of monitoring the test equipment. Calibration standards or, even better, reference samples, are used to check the calibration and to verify the stability of the instrument.

Measuring**Measuring is comparing!**

The probe signal generated at the measuring position is compared to the probe signal at the calibration standard. Using the calibration curve, the instrument converts the probe signal to the measurement result. The result is reported in the unit of the measurement of the calibration standard.

Memory

Data storage element of a microprocessor-based instrument. Information (parameter settings, calibration coefficients, measurements) is saved in the memory)  *Application Memory*.

Menu Function

Instrument functions to configure, to set up, to set or to edit an application. It can be retrieved from menu overview with the MENU key and number

of the menu function.

Menu Page

If the size of the display is not sufficient to show all data/parameters, then the remaining data/parameters will be shown in additional display images, similar to a book. These additional display images are known as menu pages and are called (opened) using the softkey PAGE.

Minimum  *Min***Minimum Value**

Lowest measured value of a test series.

Min

Lowest measurement of a test series.

Monitoring of Test Equipment

A quality assurance task. It consists of ensuring at specified intervals that the measuring system (instrument, probe) is operating properly and is still calibrated correctly, and to take corrective measures, if necessary (re-calibration of the instrument or repair ...).  *Measuring System Check*

NC

Abbreviation for insulating materials, electrically non-conducting, non-magnetizable.

NF Metals

Abbreviation for non-ferrous metals, non-magnetizable, electrically conducting.

Ni

Abbreviation for Nickel.

Normal Distribution

Gaussian normal distribution, Gaussian distribution, bell curve. Probability distribution discovered by C.F. Gauß in 1794.

If a quantity X can be classified as having normal distribution, 68.3 % of the observed values X are within the σ -interval, around the mean value μ of the quantity X . I.e., The following is valid for 68.3 % of the observed values: $\mu - \sigma \leq X \leq \mu + \sigma$. In the following figure, this interval is described by the grey area underneath the curve.

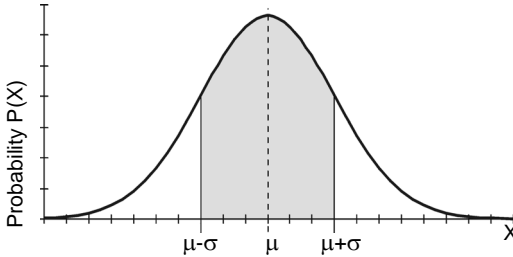

Probability distribution $P(X)$ of a quantity X with normal distribution.

The probability distribution $P(X)$ is symmetrical around the mean value μ of the quantity X . Skewness and Curvature are zero for the normal distribution.

The populations, which are tested for technical purposes, often can be classified as having approximately normal distribution. However, the following fact is of great significance: if several random samples of equal number are drawn of a population (blocks), and the mean values of these random samples (block mean values) are determined, then these mean values will always have normal distribution (central limits theorem).

The mean value of these random sample mean values (block mean values) is an estimated value ($\hat{\mu} = \bar{m}$) for the mean value μ of the population. The uncertainty of measurement u can be determined using the standard deviation of the sample mean values (since the sample mean values can be classified as having normal distribution).

The sum frequency chart shows if a quantity has normal distribution; a straight line indicates normal distribution. In the instrument, the test whether the measurement data at hand have normal distribution is carried out with the Kolmogorow-SmirnowTest (up to 30 measurements) and the Chi-Squared Test (30 measurements or more).

Normalization

Adjustment of the instrument to the material properties of the coating and/or the substrate materials (probe-dependent). Essentially, normalization specifies the zero point and the end point. A normalization is absolutely required for a correct measurement due to the electrical conductivity and the permeability of the specimen materials. The coefficients of the adapted calibration curve are stored in the open application.

Normalized Countrate Countrate

Off-Line

Status of a peripheral device connected to the instrument (printer or PC) that does not allow it to receive data.

On-Line

Ready condition of a peripheral device connected to the instrument (printer, PC) that does allow it to receive data. The connected instrument is ready for operation.

Open Block

Group of single readings where the block has not yet been ended.

Outlier Rejection

Is used to prevent the distortion of the measurement results by outlier measurements. The instrument offers two different methods of outlier rejection: Grubbs Test or Sigma Outlier Rejection (entry of a known standard deviation). Measurements recognized as outliers will not be included in the statistical evaluation.

Outliers

Measurements that are significantly smaller or greater than the rest of the measurements of a test series and that are, therefore, considered unexpected or unacceptable.

Parity

An error check method, where the cross total of all bit groups transmitted without error must always be even or odd. During data transfer, the parity bits are added to the data bits of each character or byte to be transferred. In every word, this bit is set such that the Ones of the byte always result in an even or odd number (corresponding to an even or odd parity). The type of parity must be defined prior to the data transfer. By checking the parity, the receiver can determine if bit transfer errors occurred.

PHASCOPE®

Registered trademark of the Helmut Fischer GmbH + Co.KG for the instrument using the phase-sensitive eddy current test method for coating thickness measurements.

Phase-sensitive eddy current test method  , *Eddy Current Method, phase sensitive (ISO 21968)*

Phi  *Eddy Current Method, phase sensitive (ISO 21968)*

Population

All pieces or specimens to be measured. In practical applications, for example, all parts of a production unit, batch, etc.

Precision

Agreement between the single measurement results under precisely defined test conditions. The precision is composed of repeatability and reproducibility.

Probability Chart  *Sum Frequency Chart*

Probe characteristic  *Master Characteristic (Master Calibration Curve)*

Probe Frequency

A generator feeds the probe with an alternating current of a particular frequency. The used frequency is dependent on the measurement application and the probe type.

Probe

Transducer that delivers an electrical signal to the instrument based on a particular test method. This signal is proportional to the coating thickness and is converted to a corresponding coating thickness value in the instrument according to the master characteristic and the normalization and calibration coefficients of the open application. All Fischer probes have been master-calibrated at the factory.

Quality Assurance

All measures taken by a producer to ensure a controlled production process within the established quality criteria. One aspect of it is quality control, and coating thickness measurement, in turn, is a part of quality control.

R.

Mean range across all block ranges.

$$R. = \hat{\sigma} \cdot d_2$$

R.: Mean range

$\hat{\sigma}$: Estimated standard deviation σ of the population

d_2 : Factor, depends on the random sample size can be obtained from published tables.

Random Measurement Error  *Measurement Error*

Random Sample

Small portion of a production batch taken in accordance with random sta-

tistical methods. The results of the random sample are extrapolated to the entire batch (production unit).

Range  *R*

Reference Area

Part with a known coating thickness at a defined measuring position.

Repeatability  *Repeatability Precision*

Repeatability Precision

Repeated measurements under consistent conditions at the same measurement spot have random deviations of the measurement data. Consistent conditions means, measurements according to a specified method at an identical specimen within a short time, using the same instrument, by the same operator at the same location. The standard deviation of the measurement data obtained under repeatability conditions is a measure for the repeatability precision. A large standard deviation or measurement uncertainty of an instrument means poor repeatability precision. The smaller the standard deviation, the better is the repeatability precision. The repeatability precision is dependent on the test method and the quality of the instrument, but also on the properties of the specimen. Repeatability can be improved by generating the mean value of the measurement series (*i* individ. values).

Reproducibility

Term for the differences of individual measurement results under reproducibility conditions. Reproducibility conditions refer to measurements on a specimen according to a specified method, e.g., at different times or with different instruments or with different observers or at different locations. Measurement results that have been obtained by different persons using different instruments at different locations on the identical specimen must be comparable. The comparability precision is the basis for computing the confidence interval for the expected value.

RS232 Interface

A serial interface protocol standardized originally in the United States. Employed, for instance, to connect a PC to a measuring instrument.

R

The range *R* is the difference between the maximum measurement (maximum) th_{\max} and the minimum measurement (minimum) th_{\min} of a test se-

ries.

$$R = th_{\max} - th_{\min}$$

s

The standard deviation s is a measure of the deviations of single readings of a test series from their common mean value. It is equal to the mean square deviation of the single readings from the mean value and is calculated in the following manner:

$$s = \sqrt{\frac{1}{n-1} \cdot \sum_{i=1}^n (th_i - th)^2}$$

- s: Standard deviation
- th.: Mean value of all single readings
- n: Number of single readings
- th_i: Single readings

The following figure shows that two very different test series with the same mean value can have different standard deviations.

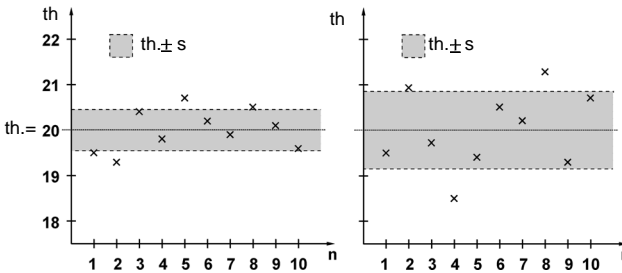

Test series with the same mean value $th.$ and different standard deviations s

sa

Deviation of the block mean values, corrected with regard to the deviations of the single readings. sa is calculated by the instrument only when the measurements were performed with fixed block size (automatic block creation enabled) and the deviations of the block mean values cannot be attributed to the deviations within the blocks, as determined by analysis of variance methods. At least 5 blocks must be present for the computation, and the spread of the block mean values around the overall mean value (s_{II}) must be significantly greater than $\hat{\sigma}$.

If, for instance, the same number of measurements is performed on several measuring spots and the measurements on each spot are combined into a block, then $s.$ is a measure for the instrument deviation (with a sufficiently smooth and hard coating surface) and sa is a product deviation with the instrument deviation eliminated.

$$s_a = \hat{\sigma} \cdot \sqrt{\frac{F_{beo} - 1}{n_{BI}}}$$

- sa: Deviation of the block mean values
- $\hat{\sigma}$: Estimated value for the standard deviation σ of the population.
- n_{BI} : Number of blocks
- F_{beo} : Quantile of F-Distribution (observed), with s_{II} as the spread of the group mean values around the overall mean value

$$F_{beo} = \frac{s_{II}}{\sigma^2} ;$$

$$s_{II} = \sqrt{n_i} \cdot \sqrt{\frac{1}{n_{BI} - 1} \cdot \sum_{BI=1}^{n_{BI}} (th_{\cdot BI} - th_{\cdot\cdot BI})^2}$$

- $th_{\cdot BI}$: Block mean value
- $th_{\cdot\cdot BI}$: Mean value of the block mean values
- n_{BI} : Number of blocks
- n_i : Block size (Number der measurements per block)

$\hat{\sigma}$

Estimated value for the standard deviation σ of the population. Will be displayed or printed only for applications with automatic block creation (fixed block size) enabled.

- $\hat{\sigma} = \frac{R}{d_2}$
- $\hat{\sigma}$: Estimated value for the standard deviation σ of the population
- R: Mean range
- d_2 : Factor, depends on the random sample size, can be obtained from published tables.

or for specification limits:

- $\hat{\sigma} = \frac{USL - LSL}{6 \cdot Cp}$
- $\hat{\sigma}$: Estimated value for the standard deviation σ of the population
- USL: Upper specification limit
- LSL: Lower specification Limit
- Cp: Capability factor (default setting 1.33)

Single Reading

Measurement result as displayed by the instrument or printed after a single measurement at the measurement spot.

Skewness

Measure for the asymmetry of a single-peak probability distribution around its mean value. A positive skewness indicates a distribution, where the peak stretches more toward values that are greater than the mean value. A negative skewness indicates a distribution, where the peak stretches more towards values that are smaller than the mean value. The skewness of symmetric distribution is zero (e.g. for normal distributions).

Specification Limits

The upper specification limit (USL) is the maximum value and the lower specification limit (LSL) is the minimum value allowed on the measurement area.

Specimen

Object on which the measurements are to be performed to determine the coating thickness.

Standard  *Calibration Standard*

Standard Deviation  *s*

Start Bit

With asynchronous serial data transfer, the start bit is transmitted prior to the data word to be transferred. With the logic One to logic Zero transition of the start bit, the receiver can be synchronized to the subsequent data bits.

Statistical Evaluation

Calculations based on the measurement data using statistical mathematical methods.

Statistics

The result of a test series, that is, the combination of a large number of single readings into few characteristic properties (e.g. mean value, standard deviation etc.).

Stop Bit

With asynchronous serial data transfer, the stop bit is added to the data word to be transferred. 1 to 2 bit logic Ones are used. After the stop bits, the transmitter remains at logic One until the start bit of the next character arrives.

Student Factor  *t*

Sum Frequency Chart

Graphic method to check for normal distribution of the measurements. A straight line in the sum frequency chart indicates normal distribution.

Sum Frequency

The sum frequency is a portion of parts (in percent) where the coating thickness is smaller or equal to a particular measurement. In a sum frequency chart (probability chart), the sum frequency can be viewed as a function of the coating thickness. Example: one realizes that 9 % of the parts have an electrical conductivity smaller or equal to 39 μm (1.56 mils).

Supervisor Code:

Password for a menu function to prevent unintended changes of the parameter settings. Password: 159.

Systematic Measurement Error  *Measurement Error***Test Method**

Procedures and process to obtain information about the properties of a specimen. The test method is based on scientific findings and depends on the measurement application.

th..

Mean value (average) of the block mean values of the selected blocks. Analogous to the arithmetic mean value (th.), here the block mean values are added together and divided by the number of evaluated blocks n_{Bl} .

$$\text{th..} = \frac{1}{n_{\text{Bl}}} \cdot \sum_{i=1}^{n_{\text{Bl}}} \text{th}_i$$

th.. Mean value of the block mean values
 n_{Bl} Number of blocks
 th_i Block mean values

th.

Mean value of the single readings, called arithmetic mean value (th., $\bar{\text{th}}$). The arithmetic mean value, the sum of all single readings d_i of a measurement series (a block), divided by the number of measurements.

$$\text{th.} = \frac{\text{th}_1 + \text{th}_2 + \text{th}_3 + \dots + \text{th}_n}{n} = \frac{1}{n} \cdot \sum_{i=1}^n \text{th}_i$$

th. Mean value (block mean value)
 n Number of single readings (of one block)
 th_i Single readings (of a block)

Tolerance Limits  *Specification Limits*

True Value  *Trueness*

Trueness

Agreement between the "true" value and the mean value of the measurement results, generally obtained under normal conditions. The "true" value is considered a value known based on mathematical theoretical approaches. Because such values are rarely present, a value traced to national or international standards is generally assumed "correct". This "correct" value is often called a "true" value.

t

The student factor t can be obtained from popular published Tables (e.g. Graf, Henning, Stange, Wilrich: Formeln und Tabellen der angewandten mathematischen Statistik; Springer-Verlag [Formulas and Tables of Applied Mathematical Statistics by Graf, Henning, Stange and Wilrich]) and is specified as follows:

$t_{(1-\frac{\alpha}{2});f}$ Example: at a confidence level of 95 % and $n > 200$ (and thus degree of freedom $f=199$, because $f = n - 1$) the student factor is $t_{97.5; 199} = 1.96$.

Two-Point Calibration  *Corrective Calibration*

u

Every instrument is subject to random measurement errors ( *Accuracy*). With a certain probability (the confidence level), the presumed "true" value (μ) of the measurement parameter lies within an interval around the measured mean value $th.$ of a test series. The interval is also called confidence interval. The boundaries of this interval define a certain range which determines the measurement uncertainty u of the mean value μ .

$$th. - u \leq \mu \leq th. + u$$

For a population at normal distribution and a pre-set confidence level $(1 - \alpha)$, the measurement uncertainty is calculated according to the following formula:

$$u = \frac{t \cdot s}{\sqrt{n}}$$

- t: Student Factor (can be obtained from any popular publication of mathematical statistics tables). At a confidence level of 95% and $n > 200$, for instance, the student distribution factor is $t_{97.5; 199} = 1.96$.
- s: Standard deviation
- n: Number of measurements

By entering the coefficient of variation (C.O.V) in place of the standard deviation s one obtains the relative measurement uncertainty u_{rel} in %.

$$u_{rel} = \frac{t \cdot V}{\sqrt{n}} [\%]$$

Unit of Measurement

Unit used for the measurement display. In coating thickness measurements, the common units of measurement are μm and mils. $100 \mu\text{m} = 3.9$ mils.

u-Scale

Scale on the right ordinate in the printout of the probability chart. Linear transformation of the measurements into standardized feature values u . The transformation serves comparison and analysis purposes. The standardized feature values are dimension-less, their arithmetic mean u is Zero and their standard deviation $\sigma(u)$ is always 1.

$$u = \frac{th - \mu}{\sigma}$$

- u: Feature value
- th: Measurement value
- μ : Mean value of population
- σ : Standard deviation of the population

USL

The upper specification limit is the maximum measurement allowed at the measurement position.

Variance

Mean squared deviation. The square root of the variance is called standard deviation (s).

$$s^2 = \frac{1}{n-1} \cdot \sum_{i=1}^n (th_i - th_{..})^2$$

s^2 : Variance
 $th_{..}$: Mean value
 th_i : Single readings
 n : Number of measurements

\hat{V}

Estimated value of the coefficient of variation.

$$\hat{V} = \frac{\hat{\sigma}}{th_{..}} \cdot 100[\%]$$

\hat{V} : Estimated value of the coefficient of variation
 $\hat{\sigma}$: Estimated value for the standard deviation σ of the population
 $th_{..}$: Mean value of the block mean values

V

Coefficient of variation (C.O.V.). The relative standard deviation as a percentage of the mean. V [%] is a characteristic process constant. A sudden change of V [%] indicates a change in the process conditions. V is calculated as follows:

$$V = \frac{s}{th_{..}} \cdot 100[\%]$$

V : Coefficient of variation
 s : Standard deviation
 $th_{..}$: Mean value

X  *Countrate*

XN  *Countrate*

Zn

Abbreviation for Zinc.

Index

A

AC adapter
 replacing from EU to US to UK 30
 replacing the plug adapter 30

Accept
 measurement value 77

Accept measurement
 menu function 160

Accessory
 notes 3

Accu *see* *Battery*

Activate
 parameter 20

Adjust
 general new 63
 to specimen 50
 Paint/Al 58
 to specimen Paint/Zn/Fe 52
 up to 2 standards 50

Adjust brightness
 menu function 167

Air value measurement 26
 enable/disable 166

Air value warning
 menu function 26, 166

APPL 7, 18

Appl. not defined! 100

Appl. template
 menu function 104

Application 1
 assigning new probe 39
 average display value 113
 calling 18
 copying 98
 corrective calibration 50
 creation 95
 define template 104
 delete all measurements 123

 delete all measurements of an
 open block 124
 delete corrective calibration 61
 deleting 99
 description 95
 disable storing measurements
 126
 edit 112
 enable/disable automatic block
 creation 117
 enable/disable specification limit
 monitoring 116
 entering name 21, 119
 evaluation 82
 i individual values 113
 linking applications 106
 meas. value resolution 120
 measurement type 121
 new 95
 normalization 44
 outlier control 113
 printing list 137
 secure/unsecure 101
 select display mode 112
 setting up 95
 specific settings 109

Application memory *see* *Application*

Application name
 parameter 119

Areas of application 5

Arrow keys 19, 26

Attention Difference between XN
 values... 181

Autom. switch-off
 menu function 170

Automatic
 parameter 115, 160

B

Base 52

Battery
 autom. switch-off 170
 changing 32

- charging time 28
- charging, using AC adapter 28
- charging, using MPG station 33
- connecting to instrument 32
- handling 28
- operation time 28, 164
- removing from instrument 32
- Baud rate
 - parameter 140
- Beep ON/OFF
 - menu function 157
- Beep tones 78
- Block
 - automatic block creation 117
 - creation 79
 - evaluation 83, 93
 - evaluation across several blocks 84
 - open, delete all measurements 124
 - printing block result 130, 131
 - view/hide 125
- Block creation
 - automatically, manually 79
- Block mean value
 - parameter 142
- Block result
 - parameter 129
 - printing 130, 131, 132
 - simple display mode 93
- Block result menu 83
 - calling 25
 - computing the statistical characteristic data *see chapter Glossary*
 - simple display mode 93
 - statistical data 87
- Brightness 167
- By probe signal
 - parameter 160

C

- Calibration 43
 - coating/substrate material adjustment 44
 - corrective calibration 50
 - delete corrective calibration 61
 - master calibration 63
 - normalization 44
- Calibration standards 50
 - handling 4
 - NC/NF/Fe 52
 - notes 4
 - Paint/Al 58
 - Paint/Zn/Fe 52
 - preparing 62
- Calling
 - application 18
 - block result menu 25
 - evaluation menu 24
 - menu function 17
- Cancelling a menu function 24
- Changing
 - battery 32
 - plug adapter at the AC adapter 30
 - simple/normal display and operating mode 161
- Character length
 - parameter 140
- Characters
 - deleting 23
- Charging battery
 - using AC adapter 28
 - using MPG station 33
- Coating thickness
 - parameter 159
- Coating/substrate material adjustment 44
- Compensation
 - of influences 43
- Connections
 - power connections, notes 1

- printer 127
- probes 35
- RS232 interface 138
- Connectors 14
 - pin-out, RS232 interface 138
- Continuous display mode
 - air value warning 166
- Contrast 167
 - parameter 167
- Control commands 146
- Control panel 7
- Copy
 - application 98
- Copy application
 - menu function 98
- Correction
 - wrong entry 22
- Corrective calibration 50
 - deleting 61
 - NC/NF 58
 - NC/NF/Fe 52
 - Paint/Al 58
 - Paint/Zn/Fe 52
- Count rate
 - display 121
 - display normalized 121
- Creation
 - new application 95
- Cursor
 - move on display page 19

D

- Data format setting 140
- Data organization 5
- Data output
 - selection for RS232 142
 - to printer 129
- Data transfer
 - air value warning 166
 - control commands 146
 - does not work 176

- key codes for remote control
 - 152
 - to instrument 146
 - to PC 144, 145
 - transfer formats 146
 - via RS232 interface 138
- Date
 - parameter 142
 - setting 169
- Deactivate
 - parameter 20
- Decimal point of the meas. value
 - 120
- Define
 - new application 95
 - new application memory 95
 - new application template 104
- DEL 23
- Del./accept block
 - menu function 125
- Delete
 - all measurements of an open block 124
 - all measurements of the open application 123
 - application 99
 - characters, numbers 23
 - corrective calibration 61
 - function settings *see Disabling*
- Delete application
 - menu function 99
- Delete block
 - menu function 124
- Delete meas. with final res
 - parameter 162
- Delete measurements
 - menu function 123
- Description
 - application 5, 95
 - areas of application 5
 - control panel 7
 - data organization 5
 - display symbols 9

- functional principle 5
- instrument connectors 14
- instrument front view 6
- instrument rear view 6
- keys 7
- softkeys 10
- terms and formulas 183
- DIP switch
 - settings for printing 127
- Disable
 - air value measurement 166
 - automatic block creation 117
 - automatic switch-off for battery operation 170
 - continuous display mode 80
 - display illumination 167
 - linking mode 106
 - outlier control 114
 - parameter 20
 - signal tone for measurement accept 157
 - spec. limit monitoring 116
- Display
 - brightness 167
 - contrast 167
 - count rate 121
 - displaying continuous measurement values 80
 - free display 80
 - illumination setting 167
 - instrument status 158
 - meas. value as coating thickness 121
 - messages 176
 - move cursor 19
 - normalized count rate 121
 - nothing on the display 176
 - scientific mode 112
 - scrolling through pages 19
 - select display mode 112
 - statistic mode 113
 - symbols 9, 78
 - view/hide block 125

- Display format
 - menu function 120
- Display message
 - Attention Difference between XN values... 181
 - measured air value... 180
 - Measurement data out of... 180
 - Measurement is outside... 182
 - Missing probe! 180
 - Normalization, With probe... 180
 - Standard sequence invalid! ... 181
- Display mode
 - menu function 121
 - selecting 112
 - toggle between simple and normal 161

E

- Edit
 - application 112
- EMC 2
- Enable
 - air value measurement 166
 - automatic block creation 117
 - automatic switch-off for battery operation 170
 - continuous display mode 80
 - display illumination 167
 - linking mode 106
 - outlier control 114
 - parameter 20
 - signal tone for measurement accept 157
 - spec. limit monitoring 116
- Ending
 - menu function 23
- Entry
 - application name 119
 - characters, numbers 21
 - correction 22
 - numbers 21

Environment conditions 2
Error messages 176
ESC 24
ESG...
 probe handling 37
european
 parameter 169
Evaluation 82, 83
 block 83, 93
 computing the statistical characteristic data *see chapter Glossary*
 final result 88, 90, 93
 histogram 92
 printing histogram 136
 printing statistical characteristic data, final result 133, 134
 printing sum frequency chart 135
 several blocks 84
 statistical characteristic data 87
 sum frequency chart 91
Evaluation menu 82
 calling 24
Exiting
 menu function 23
Ext. start
 parameter 81, 160
External start 81

F

fast
 parameter 164
feature entering 21
Final result
 computing of the statistical characteristic data *see chapter Glossary*
 printing statistical characteristic data 133, 134
 simple display mode 93
 statistical characteristic data 88

Fixed block sized
 parameter 117
Formulas 183
Free display
 disable 80
 enable 80
Free display mode
 menu function 80
Functional principle 5

G

Glossary 183
Graphical evaluation
 histogram 92
 printing histogram 136
 printing sum frequency chart 135
 sum frequency chart 91

H

Handling
 calibration standards 4
 probes 35
 probes ESG... 37, 38
Handshake
 parameter 140
Hide
 block 125
High
 parameter 164
High resolution
 parameter 120
Histogram 92
 printing 136
How to measure? 75
How to start? 75

I

i individ. values
 parameter 114
Illumin. time
 parameter 167

- Inch units
 - parameter 159
- Influences
 - compensation 43
 - to measurement 75
- Input sigma
 - parameter 115
- Instrument
 - automatic switch-off for battery operation 170
 - connecting battery 32
 - connectors 14
 - display illumination 167
 - display symbols 9
 - does not measure 176
 - enable/disable air value warning 166
 - enable/disable signal tone 157
 - front view 6
 - language setting 27
 - low power mode 164
 - measurement accept 160
 - memory distribution 158
 - On/Off 15
 - operation 15
 - rear view 6
 - receiving control commands 146
 - removing battery 32
 - RS232 data format settings 140
 - RS232 data output settings 142
 - set date/time 169
 - settings 154
 - settings for printer 128
 - settings for printing 129
 - simple/normal display and operating mode 161
 - symbols during measurement 78
 - unit selection 159
- Instrument settings 154
 - battery operation time 164
 - date/time 169
 - display illumination 167

- enable/disable air value warning 166
- enable/disable automatic switch-off (battery operation) 170
- enable/disable signal tone 157
- measurement speed 164
- normal/simple display and operating mode 161
- printing 137
- type of measurement accept 160
- units 159

Instrument status

- display 158
- menu function 158

Intended use 1

Interface *see RS232 interface*

K

- Key codes 152
- Keys 7
 - arrow keys 19
 - softkeys 10

L

- Language
 - menu function 27
 - selecting 27
- Limit monitoring *see Specification limit monitoring*
- Link applications 106
 - menu function 106
 - parameter 107
- Linking mode
 - on/off 106
- Low
 - parameter 164
- Low power mode
 - air value warning 166
 - menu function 164
- Low resolution
 - parameter 120

M

- Malfunction 176
- Master calibration 63
 - menu function 63, 71
 - NC/NF 71
 - NC/NF/Fe 63
 - Paint/Al 71
 - Paint/Zn/Fe 63
- Master characteristic 63
- Material adjust
 - NC/NF 58
 - NC/NF/Fe 52
 - Paint/Al 58
 - Paint/Zn/Fe 52
- MEAS 24
- Meas. per block
 - parameter 118
- measured air value... 180
- Measurement 75
 - acoustic signals 78
 - air value 26
 - attention 77
 - creating a block 79
 - data transfer via RS232, after 145
 - data transferring via RS232, during 144
 - display symbols 78
 - influences 75
 - measurement accept 77
 - performing 77
 - prerequisite 75
 - printing after 130
 - printing during 130
 - quick path 75
 - speed 164
 - with continuous display 80
 - with external start 81
 - with probes ESG... on curved specimens 38
 - with probes ESG... on flat specimens 38
- Measurement accept 77
 - acoustic signals 78
 - enable/disable signal tone 157
 - external start 81
 - setting 160
- Measurement data out of... 180
- Measurement is outside... 182
- Measurement probes
 - connection 35
 - ESG..., handling 37
 - handling 35
- Measurement values
 - acceptation 77
 - continuous display 80
 - creating a block 79
 - delete all 123
 - delete all of an open block 124
 - delete last 23
 - display as coating thickness value 121
 - display as countrate 121
 - display as normalized countrate 121
 - do not store 126
 - evaluation 82
 - number of decimal places 120
 - printing 132
 - type 121
 - view/hide block 125
 - viewing 26
 - wrong 176
- Measuring probes
 - notes 3
 - see Measurement probes or Probe*
- Medium resolution
 - parameter 120
- Memory distribution
 - instrument 158
- Memory *see Application*
- MENU 8, 17
- Menu function
 - accept measurement 160

- adjust brightness 167
- air value warning 26, 166
- Appl. template 104
- Autom. switch-off 170
- beep ON/OFF 157
- calling 17
- cancelling 24
- copy application 98
- del./accept block 125
- delete application 99
- delete block 124
- delete measurements 123
- display format 120
- display mode 121
- ending 23
- exiting 23
- free display mode 80
- instrument status 158
- language 27
- link applications 106
- low power mode 164
- master calibration 63, 71
- modify application 112
- output to printer 129
- output to RS232 142
- printer selection 128
- RS232 configuration 140
- secure/unsec. appl. 101
- select units 159
- set date/time 169
- set up new appl 95
- simple/normal mode 161
- store measurements 126

Message

- Attention Difference between XN values... 181
- Measured air value... 180
- measurement data out of ... 180
- Measurement is outside... 182
- Missing probe! 180
- Normalization, With probe... 180
- Standard sequence invalid! ... 181

- Metric
 - parameter 159
- Missing probe! 180
- Modify application
 - block creation 117
 - enable/disable spec. limit monitoring 116
 - enter application name 119
 - i individ. values 113
 - menu function 112
 - outlier control 113
 - select display mode 112
- Monitor limits
 - parameter 116
- Moving cursor on display page 19

N

- Name entry 21, 119
- Navigation 15
- NC/NF
 - adjust to specimen 58
 - corrective calibration 58
 - master calibration 71
 - standards 58
- NC/NF/Fe
 - adjust to specimen 52
 - corrective calibration 52
 - master calibration 63
 - standards 52
- Normal meas. modus
 - parameter 162
- Normalization 44
- Normalization, With probe... 180
- Notes 1
 - accessory 3
 - battery 28
 - calibration standards 4
 - environment conditions 2
 - operating personnel 1
 - operation 2
 - power connection 1
 - probes 3

- Numbers
 - deleting 23
 - entering 21
- O**
- Off
 - parameter 157
- Offline 130, 145
- Offset 118
- Offset Zn/Fe
 - Parameter 118
- OK 23
- On
 - parameter 157
- Online 130, 144
- Open
 - application 18
 - block result menu 25
 - evaluation menu 24
 - menu function 17
- Operating mode
 - toggle between simple and normal 161
- Operating personnel requirements 1
- Operation
 - basics 15
 - calling block result menu 25
 - calling evaluation menu 24
 - entering name 21
 - entering numbers 21
 - instrument 15
 - moving cursor on display page 19
 - navigation 15
 - overwriting wrong entry 22
 - probes 35
 - scrolling through display pages 19
 - selecting parameters 20
 - softkeys 16

- Operation areas 1
- Outlier control 113
 - parameter 114
- Output to printer
 - menu function 129
- Output to RS232
 - menu function 142
- Overview
 - application specific settings 109
 - instrument settings 154
- Overwriting a wrong entry 22

P

- Page 19
- Paint/Al
 - adjust to specimen 58
 - corrective calibration 58
 - master calibration 71
 - standards 58
- Paint/Zn/Fe
 - adjust to specimen 52
 - corrective calibration 52
 - master calibration 63
 - standards 52
- Parameter
 - application name 119
 - automatic 115, 160
 - baud rate 140
 - block mean value 142
 - block result 129
 - by probe signal 160
 - character length 140
 - coating thickness 159
 - contrast 167
 - date 142
 - delete meas. with final res 162
 - enabling/disabling 20
 - european 169
 - ext. start 81, 160
 - fast 164
 - fixed block size 117
 - handshake 140
 - high 164

high resolution 120
i individ. values 114
illumin. time 167
inch unit 159
input sigma 115
link applications 107
low 164
low resolution 120
meas. per block 118
medium resolution 120
metric 159
monitor limits 116
normal meas. modus 162
off 157
Offset Zn/Fe 118
on 157
outlier control 114
parity 140
pause (sec) 160
readings 142
scientific mode 112
selecting 20
separator 142
simple meas. mode 162
single readings 129
slow 164
statistic mode 113
std. dev. 142
stop bits 140
store meas. data 126
th 121
U.S. format 169
X 121
XN 121
Parity
parameter 140
Path to measurement 75
Pause (sec)
parameter 160
Power connection
notes 1
Preparing
calibration standards 62

Printer
connection 127
does not print 176
selecting data output 129
selecting printer type 128
Printer selection
menu function 128
Printing 127
after measurement 130
application list 137
block result 131, 132
during measurement 130
final result, statistical characteris-
tic data 133, 134
histogram 136
instrument settings 137
later 130
no printout 176
settings 127
single readings 132
sum frequency chart 135
Probability chart *see Sum frequen-
cy chart*
Probe
adjust to specimen 50
assigning to the open application
39
coating/substrate material adjust-
ment 44
connection 35
corrective calibration 50
does not measure 176
get reference value 26
handling 35
master calibration 63
measure reference value 26
new, assigning to the open appli-
cation 39
normalization 44
notes 3
type ESG... 37
Probe characteristic 63
Probes ESG...
adjust to specimen 52

- corrective calibration 52
- handling 37, 38
- master calibration 63
- measurement on curved specimens 38
- measurement on flat specimens 38

Q

- Quit entries 23

R

- Readings
 - parameter 142
- Remote control
 - key codes 152
- Removing
 - battery 32
- Replacing
 - battery 32
 - plug adapter at the AC adapter 30
- Requirements on the operating personnel 1
- RS232 configuration
 - menu function 140
- RS232 interface
 - connection 138
 - connector pin-out 138
 - control commands 146
 - data format setting 140
 - data output 142
 - data transfer 138
 - data transferring after measurement 145
 - data transferring during measurement 144
 - key codes for remote control 152
 - send control commands to instrument 146
 - transfer formats 146

- RS232 *see RS232 interface*

S

- Saturation 52, 58
- Scientific mode
 - parameter 112
- Scrolling through display pages 19
- Secure
 - application 101
 - unsecure application 102
- Secure/unsec. appl.
 - menu function 101
- Select units
 - menu function 159
- Selection
 - application template 104
 - battery operation time 164
 - display mode 112
 - language 27
 - meas. value resolution 120
 - measurement speed 164
 - measurement type 121
 - parameter 20
 - printer type 128
 - type of measurement accept 160
 - units 159
- Separator
 - parameter 142
- Set date/time
 - menu function 169
- Set up new Appl.
 - menu function 95
- Setting up
 - new application 95
 - new application template 104
- Settings
 - application specific 109
 - battery operation time 164
 - date/time 169
 - display illumination 167
 - instrument 154

- language 27
- measurement accept 160
- measurement speed 164
- printer type 128
- printer, DIP switch 127
- RS232 data format 140
- specific for application memory 109
- units 159
- Signal tones
 - during measurement 78
 - enable/disable 157
- Signalisation
 - in the display 78
- Simple meas. mode
 - parameter 162
- Simple/normal mode
 - menu function 161
- Single readings
 - parameter 129
 - printing 132
 - see *Measurement values*
- Slow
 - parameter 164
- Softkeys
 - description 10
 - list 10
 - use, handling 16
- Specification limit monitoring 116
 - enable/disable 116
- Standard sequence invalid! ... 181
- Standards
 - preparing 62
- Statistic mode
 - parameter 113
- Statistical characteristic data 87
 - computing see *chapter Glossary*
- Statistical evaluation of the measurements 82
- Std. dev.
 - parameter 142

- Stop bits
 - parameter 140
- Storage
 - no measurements 126
- Store meas. data
 - parameter 126
- Store measurements
 - menu function 126
- Sum frequency chart 91
 - printing 135
- Switching Off
 - instrument 15
 - see also *Disable*
- Switching On
 - instrument 15
 - see also *Enable*
- Symbols 9

T

- Technical data 171
- Template
 - define for new applications 104
- Terms 183
- th
 - parameter 121
- Time
 - setting 169
- Toggle
 - normal/simple display and operating mode 161
- Transfer formats 146

U

- U.S. format
 - parameter 169
- Unit selection 159
- Unsecure application 102

V

- View
 - block 125
 - measurements 26

X

X

parameter 121

XN

parameter 121